

Installation & Operation

P/N 1-960548-00
Edition 1
October 2001

EasyCoder 501 S Bar Code Label Printer

 **intermec**
Technologies Corporation

A **UNOVA** Company

Contents

Preface	Table of Contents	1
	Copyright Information	4
	Trademarks	4
	FCC Notice (U.S.A.)	5
	DOC Notice (Canada).....	5
	GS Notice (Germany)	5
	Declaration of Conformity (CE)	6
1. Introduction	Models	7
	Supplementing Manuals	8
	Safety Requirements	8
	Product Labeling	8
2. Print a Label	Introduction.....	9
	Using Intermec Fingerprint	12
	Using Intermec Direct Protocol	15
3. Installation	Unpacking	16
	Front View	17
	Rear View	18
	Media Compartment	19
	Print Unit.....	21
	Connections	22
	• Power	22
	• Computer	22
	Controls and Indicators	23
	• Control Lamps	23
	• Display	23
	• Keyboard	23
	• Beeper.....	24
4. Starting Up	Startup Files	25
	Switching On the Printer	26
	Display Messages at Startup.....	26
5. Media Load	Tear-Off (Straight-through)	27
	Cut-Off	31
	Peel-Off (Self-strip).....	35
	Internal Batch Takeup	40
	External Supply	45

EasyCoder 501 S
Installation & Operation
Edition 1, October 2001
Part No. 1-960548-00

Contents, cont.

6. Thermal Transfer Printing	Ribbon Load	47
7. Setting Up the Printer	Description	51
	Default Setup	52
	Reading the Current Setup.....	52
	Setup Parameters:.....	53
	• Contrast	53
	• Serial Communication:	53
	- Baud Rate.....	53
	- Parity	54
	- Character Length.....	54
	- Stop Bits	54
	- Flow Control	54
	- New Line.....	56
	• Detection:	56
	- LSS Adjustment.....	56
	- Feed Adjustment.....	57
	• Service:.....	59
	- Media Size	59
	- Media Type	63
	- Print Defs	64
	- Performance.....	68
	- Memory Allocation.....	68
8. Setup Mode	Setting Up EasyCoder 501 S	69
9. Intermec Shell Startup Program	Introduction.....	70
	Starting with Intermec Shell.....	72
	Intermec Shell v.4.01 Standard, Main Diagram.....	75
	Intermec Shell v.4.01 Standard, Setup Diagram	76
	Terminal Setup	77
	• Starting Terminal Setup	77
	• Solving Communication Problems.....	77
	• Using Terminal Setup.....	78
	• Selecting an Application	79
	• Changing the Setup	80
	• Exiting Terminal Setup	81
	• Setup Parameters	82
	Line Analyzer	84
10. Options	Introduction.....	85
	Cutter.....	85
	Memory Card Adapter	87

Contents, cont.

10. Options, cont.	Liner Takeup Unit.....	89
	Internal Batch Takeup Guide.....	89
	Media Roll Retainer	89
	External Media Guides	89
	Scaleable Fonts Kit.....	90
	Clear Door Panel	93
	Interface Boards	93
11. Troubleshooting	Troubleshooting List.....	94
12. Maintenance	Printhead Cleaning.....	95
	External Cleaning.....	98
	Cleaning the Cutter	99
	Printhead Replacement	100
13. Adjustments	Label Stop Sensor.....	101
	Display Contrast	105
	Printhead Pressure.....	106
Appendix 1	Technical Data	107
Appendix 2	Media Specifications	109
	• Direct Thermal Media.....	109
	• Thermal Transfer Media	109
	• Media Roll Size.....	110
	• Media:.....	111
	- Non-Adhesive Strip.....	111
	- Self-Adhesive Strip.....	112
	- Self-Adhesive Labels.....	113
	- Tickets with Gap.....	114
	- Tickets with Black Mark.....	115
	• Transfer Ribbons.....	116
Appendix 3	CPU Board.....	117
	• Accessing the CPU Board.....	117
	• Safety Instructions	118
	• Potentiometers.....	118
Appendix 4	Interfaces:.....	120
	• Standard Interface "uart1:"	120
	• Parallel Interface Board (option)	127

Information in this manual is subject to change without prior notice and does not represent a commitment on the part of Intermec Printer AB.

© Copyright Intermec Printer AB, 2001. All rights reserved. Published in Sweden.

EasyCoder, EasyLAN, Fingerprint, and LabelShop are registered trademarks of Intermec Technologies Corp. The word Intermec, the Intermec logo, InterDriver, PrintSet, and Duratherm are trademarks of Intermec Technologies Corp.

Centronics is a registered trademark of Genicom Corporation.

Microsoft is a registered trademark of Microsoft Corporation.

Speedo is a trademark of Bitstream, Inc.

Torx is a registered trademark of Camcar Division of Textron Inc.

TrueType is a trademark of Apple Computer Inc.

Unicode is a trademark of Unicode Inc.

Windows is a trademark of Microsoft Corporation

FCC Notice (United States of America)

WARNING

This equipment generates, uses, and can radiate radio frequency energy and if not installed and used in accordance with the instructions manual, may cause interference to radio communications. It has been tested and found to comply with the limits for a Class A computing device pursuant to Subpart J of Part 15 of FCC Rules, which are designed to provide reasonable protection against such interference when operated in a commercial environment. Operation of this equipment in a residential area is likely to cause interference in which case the user at his own expense will be required to take whatever measures may be required to correct the interference.

DOC Notice (Canada)

Canadian Dept. of Communication REGULATIONS COMPLIANCE (DOC-A)

This digital apparatus does not exceed the class A limits for radio noise emissions from a digital apparatus as set out in the radio interference regulations of the Canadian Department of Communication.

Ministère des Communications du Canada CONFORMITE DE REGLEMENTS (DOC-A)

Le présent appareil numérique n'émet pas de bruits radio-électriques dépassant les limites applicables aux appareils numériques de classe A prescrites dans le règlement sur brouillage radioélectrique édicté par le Ministère des Communications du Canada.

GS Notice (Germany)

ALLGEMEINE VORSCHRIFT

Reparaturen oder sonstige Eingriffe, die sich nicht auf normale Bedienung der Maschine beziehen, dürfen ausschließlich nur von einem ausgebildeten, zuständigen Fachmann vorgenommen werden.

Declaration of Conformity

We,

Intermec Printer AB
Idrottsvägen 10
Box 123
S-431 22 Mölndal
Sweden

declare under our sole responsibility¹ that the product

EasyCoder 501 S

to which this declaration relates
is in conformity with the following standard

EN 60 950, 1992
EN 50 081-1, 1992
EN 55 022, Class B
EN 50 082-2, 1995
ENV 50 140, 10 V/m
ENV 50 204, 10 V/m
ENV 50 141, 10 V/m
EN 61 000-4-2, 6 kV (Con), 8 kV (Air)
EN 61000-4-4, 2 kV power lines, 1 kV signal lines

following the provisions of Directives

89/336/EEC and 73/23/EEC

Mölndal 1998-09-01



.....
Hans Lindén
President

¹/. Intermec assumes no responsibility regarding the CE Directive if the printer is handled, modified, or installed in other manners than those described in Intermec's manuals.

Introduction

Models

The Intermec EasyCoder 501 is a series of modular multipurpose thermal transfer/direct thermal printers. They come in four main models, each with its own Installation & Operation manual:

- **EasyCoder 501 S** (*Standard*) is an 8 or 11.81 dots/mm (203.2 or 300 dpi) printer mainly intended to be controlled by a host computer using standard or custom-made application software, for example the various Intermec LabelShop label-design programs for Microsoft Windows. Being a low-cost alternative, it has a somewhat lower print speed and fewer options than the other members of this printer family. EasyCoder 501 S can be fitted with an optional scaleable fonts kit that allows the use of outline fonts in Speedo and TrueType format. The EasyCoder 501 S is distinguished by the single Print key on its front panel.
- **EasyCoder 501 E** (*Enhanced*) offers higher print speed than EasyCoder 501 S. The larger number options in regard of media handing and computer connection makes this printer a highly flexible alternative. It is recommended for installations, where you want to switch between different application programs, or create your own programs in the built-in Intermec Fingerprint programming language. EasyCoder 501 E can, as an option, be fitted with a scaleable fonts kit that allows the use of outline fonts in Speedo and TrueType format. This printer model can easily be recognized by its 22-key membrane-switch keyboard.
- **EasyCoder 501 LinerLess** is an 8 dots/mm (203.2 dpi) EasyCoder 501 E that has been specially adapted to print on direct thermal linerless media, which is torn off manually or cut off using an optional cutter. Linerless printing eliminates the liner (backing paper), that usually protects the adhesive side of self-adhesive labels, and is thus more economical with 60% more labels per roll, which gives fewer media reloads. Variable label length allows for fewer label sizes in stock. The environment also benefits from less waste. Linerless media gives higher resistance against chemicals, scratching, and UV-light and a darker print image with longer life than common direct thermal labels with liner.
- **EasyCoder 501 SA** (*Stand-Alone*) is just as quick and flexible as the EasyCoder 501 E model, but is fitted with a special “Stand-Alone” software, which allows the printer to be operated independently, without any computer connection. This printer model is fitted with a large built-in alphanumeric keyboard.

Supplementing Manuals

The following manuals may also be of interest to the operator or programmer:

- Intermec EasyCoder 501 S, User's Guide (multi-lingual)
- Intermec Direct Protocol v6.13, Programmer's Guide
- Intermec Fingerprint v6.13, Programmer's Guide
- Intermec Fingerprint v6.14, Reference Manual
- Intermec LabelShop, various manuals

Safety Requirements

Intermec assumes no responsibility regarding the CE Directive if the printer is handled, modified, or installed in any way other than that described in Intermec's manuals.

Caution

- Read this manual carefully before connecting the printer.
- Moving parts are exposed when the side door is open, so ensure that the door is closed before you operate the printer.
- Do not open the front/left-hand cover. Dangerous voltage!
- Do not remove the bottom plate. Dangerous voltage!
- Do not put your fingers inside the print mechanism when the power is on.
- Place the printer on an even surface which can support its weight of approximately 15 kg (33 pounds) plus supplies.
- Do not spray the printer with water. If you are using a hose to clean the premises in an industrial environment, remove the printer or protect it carefully from spray and moisture.
- Carefully read the warning text on the envelope before using a cleaning card.

Product Labeling

The machine label is attached to the printer's rear plate and contains information on type, model, and serial number as well as AC voltage. It also contains various signs of approval.

Print a Label

Introduction

This chapter will help you to produce a label within minutes of unpacking your printer and it will show you how the Intermed Fingerprint programming language and the Intermed Direct Protocol make creating label formats an easy task.

If you are new to EasyCoder printers, read the rest of the manual before returning here.

In addition to the Intermed Direct Protocol and the Intermed Fingerprint programming language, the EasyCoder 501 printers also supports the InterDriver printer driver for various versions of Microsoft Windows. After you select the Windows Driver option in Intermed Shell, you can use the EasyCoder 501 printer the same way as you use any other printer to produce printouts from any standard Windows program.

Connecting Printer and Host

In the following examples we assume that you are using an ASCII terminal or a PC with a terminal program, for example Microsoft HyperTerminal, as a host. We also assume that you are using the standard RS-232 serial interface to connect your printer with the host.

The printer contains a powerful microprocessor which is controlled by the Intermed Fingerprint programming language. The connected PC is only used as a non-intelligent terminal for sending instructions to the printer and to display the responses from the printer on a screen.

Intermed provides optional communication cables for connecting the printer to most PCs. Refer to Appendix 4 for wiring diagrams.

Introduction, cont.

Setup

By default, the printer is set up for the following serial communication protocol on communication port "uart1":

Baud rate:	9600
Character length:	7
Parity:	none
Stop bits:	2
Flowcontrol:	XON/XOFF
New line:	CR/LF

If you want to change any of these values, refer to Chapter 7, "Setup Mode." Set up the host computer for the same communication protocol as the printer.

Media Supply

Load the printer with labels at least 52.8 mm (2.08 inches) wide and at least 70 mm (2.75 inches) long, see Chapter 5. In case of thermal transfer printing, also load a suitable thermal transfer ribbon, see Chapter 6.

If the printout becomes too light or too dark, you will need to change the paper type parameter, For help, see Chapter 7.

Startup and Communications Check

Switch on the printer. Provided the printer is fitted with the Intermec Shell startup program, after initialization the countdown menu will appear in the display window, for example:

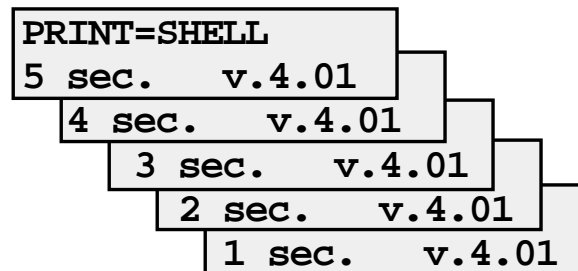

Do not take any action. By default, the display window will show the following message when the countdown is completed:



If this message is not shown, refer to "Selecting an Application" in Chapter 9 for information on how to select the "Fingerprint" application.

Introduction, cont.

Check that the printer and your terminal or PC have a working communication by typing the following instruction on the host:

BEEP ↵ (↵ = carriage return)

The printer should respond by returning **ok** to the host screen and emit a short beep. If not, check the communication setup of the printer and the host.

The next two steps demonstrate the printer's ability both to feed out the media and to pull it back. Type:

FORMFEED 300 ↵

The printer will feed out a short piece of the label. Then order the printer to pull back the label to its original position by typing:

FORMFEED -300 ↵

After loading a new supply of label stock, the printer should always be allowed to adjust itself according to the size and characteristics of the label and liner. Type:

TESTFEED:TESTFEED ↵

The printer will feed out two labels while adjusting its sensors and media feed mechanism.

Tear off the labels by grabbing the outer (right) edge and pulling downwards.

Now you are ready to start programming your first label.

Using Intermec Fingerprint

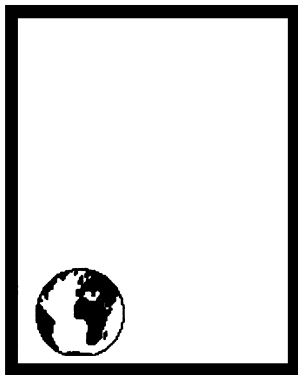
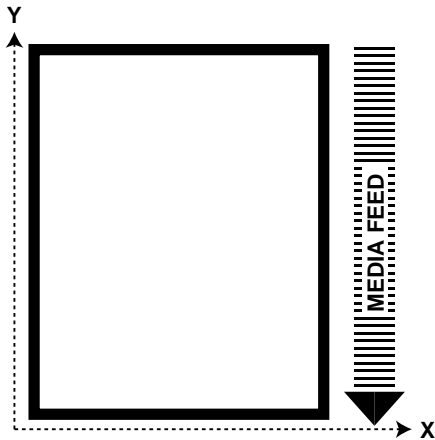

The label we will design in Intermec Fingerprint will contain a box, an image, a bar code, and a line of text. Note that the illustrations are not reproductions of the label, but are merely intended to show the principles of label editing.

Printing a Box

Let us start by printing a box 430 dots high and 340 dots wide with a 15 dot line thickness. The box is inserted at position X=10; Y=10:

```
NEW
10  PRPOS 10, 10 ↵
20  PRBOX 430,340,15 ↵
200 PRINTFEED ↵
300 END ↵
RUN ↵
```

Note: The printer does not execute the program until you have typed RUN ↵.

Printing an Image

Now we add the image "GLOBE.1" after changing the print coordinates to X=30; Y=30.

Note that the characters enclosing the word GLOBE.1 are quotation marks (ASCII 034 decimal/22 hex) and indicate a string expression (text) as opposed to a numeric expression (value). The same applies to bartypes, bar code input data, barfonts, text fonts, and input to text fields later in this chapter.

```
30  PRPOS 30,30 ↵
40  PRIMAGE "GLOBE.1" ↵
RUN ↵
```

Printing a Bar Code

You need to choose a bar code type before you can print a bar code. Note there is no blank space in the bartype name. Then provide the input data to the bar code.

```
50  PRPOS 75,270 ↵
60  BARTYPE "CODE39" ↵
70  PRBAR "ABC" ↵
RUN ↵
```

Intermec Finger- print, cont.

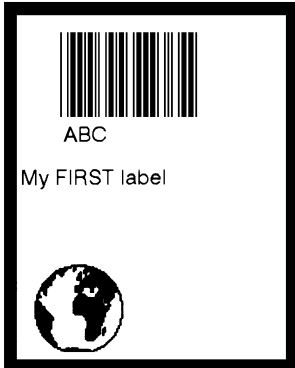
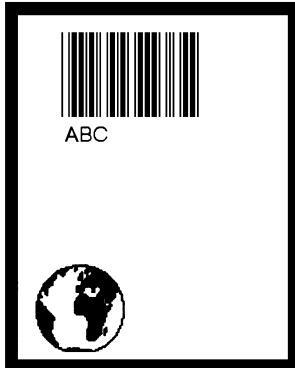

Printing Human Readables

To get human readable text printed under the bar code, add these lines which enable bar code interpretation and select a font for it:

```
1   BARFONT ON ↵
2   BARFONT "SW030RSN.1" ↵
RUN ↵
```

Printing a Line of Text

Add text at position X=25; Y=220, select a font, and finally provide the actual text:

```
80  PRPOS 25,220 ↵
90  FONT "SW030RSN.1" ↵
100 PRTXT "My FIRST Label" ↵
RUN ↵
```

Listing the Program

To view the whole program, type:

```
LIST ↵
```

The lines will be listed in ascending order on the screen of your PC:

```
1   BARFONT ON
2   BARFONT "SW030RSN.1"
10  PRPOS 10,10
20  PRBOX 430,340,15
30  PRPOS 30,30
40  PRIMAGE "GLOBE.1"
50  PRPOS 75,270
60  BARTYPE "CODE39"
70  PRBAR "ABC"
80  PRPOS 25,220
90  FONT "SW030RSN.1"
100 PRTXT "My FIRST label"
200 PRINTFEED
300 END
ok
```

Intermec Fingerprint, cont.



Changing a Program Line

If you want to change a program line, simply rewrite the line using the same line number. For example, move the text to the right by rewriting line 80 with a different X-coordinate:

```
80    PRPOS 75,220 ↵  
RUN  ↵
```

Saving the Program

If you want to save your first attempt, issue the following command.

```
SAVE "LABEL1" ↵
```

Your program will be saved in the printer's permanent memory under the name:

```
LABEL1 . PRG
```

Loading the Program

If you want to use this label later, for example after having created more programs, type:

```
LOAD "LABEL1 . PRG" ↵  
RUN  ↵
```

A new copy of the label will be printed.

The Intermec Fingerprint offers many more advanced functions that allow you to create sophisticated application programs or to emulate other printer protocols. For more information on the subject of programming, please refer to the documentation of the Intermec Fingerprint programming language.

Using Intermec Direct Protocol

You can use Intermec Direct Protocol in many ways. This section shows you how to use Intermec Direct Protocol to create the same label as the one you created using Intermec Fingerprint in the previous section. You will first create the format and then provide input data to the variable fields. Note that many of the commands are abbreviated. We assume that you use Intermec Shell to enter Intermec Direct Protocol. For help, see “Starting Up with Intermec Shell” in Chapter 9.

First, create a format:

```
LAYOUT INPUT "tmp:LABEL1" ↵      (start format recorder)
BF ON ↵                            (enable bar code interpretation)
BF "SW030RSN.1" ↵                  (select bar code font)
PP 10,10 ↵                          (insertion point for box field)
PX 430,340,15 ↵                    (create a box)
PP 30,30 ↵                          (insertion point for image field)
PM "GLOBE.1" ↵                     (select image)
PP 75,270 ↵                        (insertion point for bar code field)
BT "CODE39" ↵                      (select bar code type)
PB VAR1$ ↵                          (variable input data to bar code field)
PP 75,220 ↵                        (insertion point for text field)
FT "SW030RSN.1" ↵                 (select text font)
PT VAR2$ ↵                          (variable input data to text field)
LAYOUT END ↵                        (save format)
```

Then add the variable data and a print instruction:

```
LAYOUT RUN "tmp:LABEL1" ↵          (select format)
<STX>                               (start of input data, ASCII 02 dec.)
ABC ↵                               (variable input data to VAR1$)
My FIRST label ↵                   (variable input data to VAR2$)
<EOT>                               (end of input data, ASCII 04 dec.)
PF ↵                               (print one label)
```



Installation

Unpacking

Before you install the printer, examine the package for possible damage or missing parts:

- Open the box and lift the printer out.
- Check that the printer has not been visibly damaged during transportation. Keep the packing materials in case you need to move or reship the printer.
- Check the label on the printer's rear plate, which gives the voltage, the part number, and the serial number.
- Check that any options you ordered are included.
- Check that all the accessories are included. As standard, the box contains:
 - Intermec EasyCoder 501 S printer
 - Power cord
 - Quality check card
 - Cleaning card
 - Short strip of labels¹
 - Starter pack of thermal transfer ribbon (thermal transfer models only)¹
 - Adapter for 3-inch media roll core
 - User's Guide (multilingual)
 - Installation & Operation manual
 - Supporting software and product information on CD.
- Check that the power cord is appropriate for the local standard. The printer works within 100 to 240 VAC, 50 to 60 Hz.

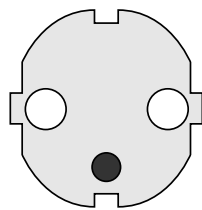

*European-type
230 VAC plug*

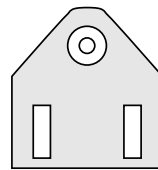

*US/Canadian-type
115 VAC plug*

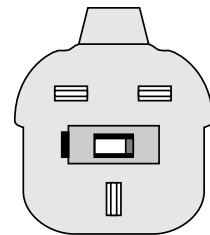

*GB-type
230 VAC plug*

If the printer has been damaged in any way during transportation, complain to the carrier immediately.

If the delivery is incorrect or any parts are missing, report it immediately to the distributor.

¹/. Type and quantity may vary, or labels/ribbon may be omitted completely, depending on area of distribution.

Front View

At the front of the printer are the display window, the control lamps, and a Print key. These features allow the operator to control the printer manually, in addition to the remote control facilities offered by the Intermec Fingerprint programming language and Intermec Shell.

There are also a connector for an optional cutter which replaces the front door and a slot for accessing an optional memory card adapter.

The printed labels, tickets, or tags are presented at the front of the print mechanism.

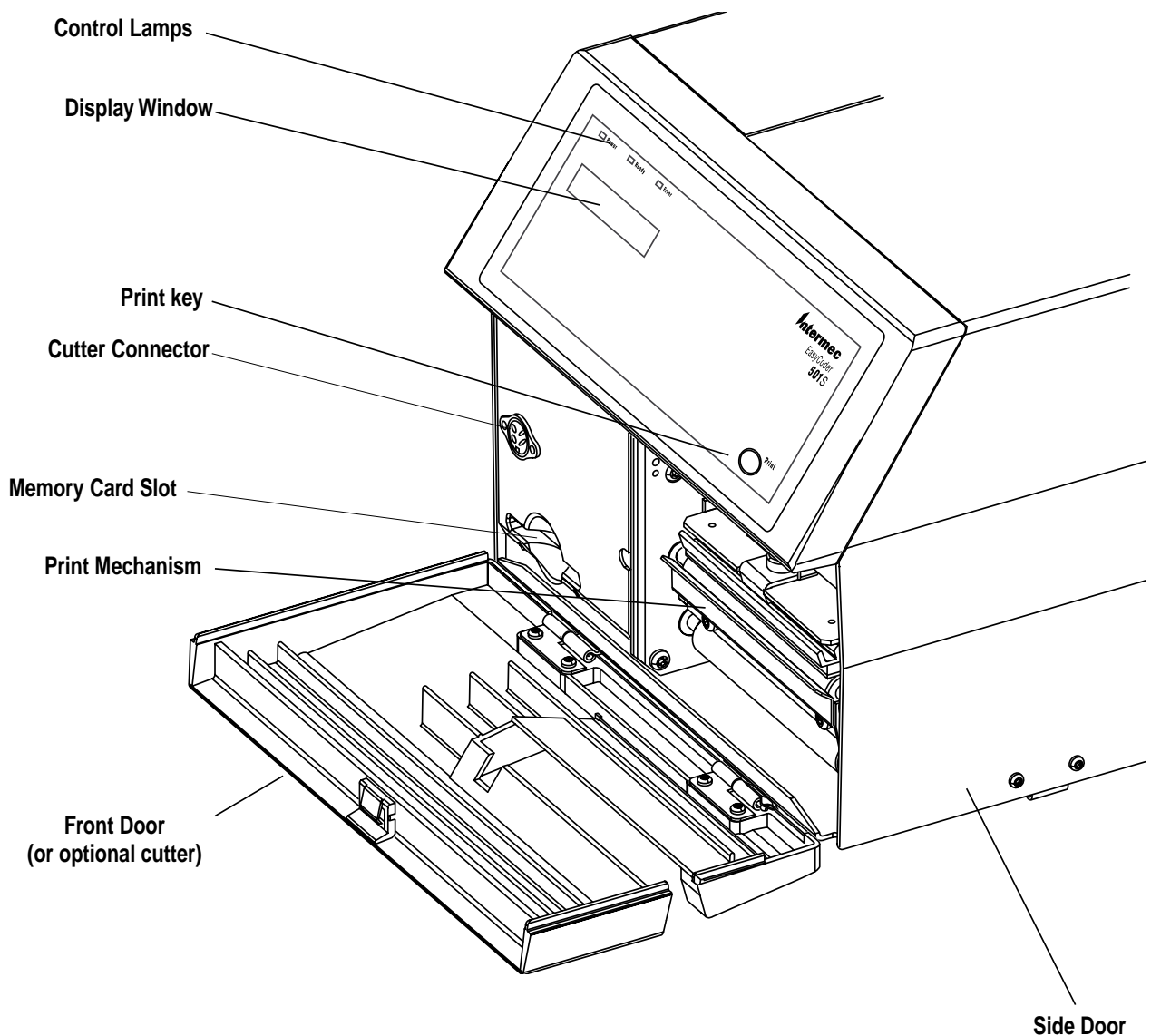

Rear View

The rear plate contains the On/Off switch, the AC power cord receptacle, the voltage switch, the standard serial interface, and various slots.

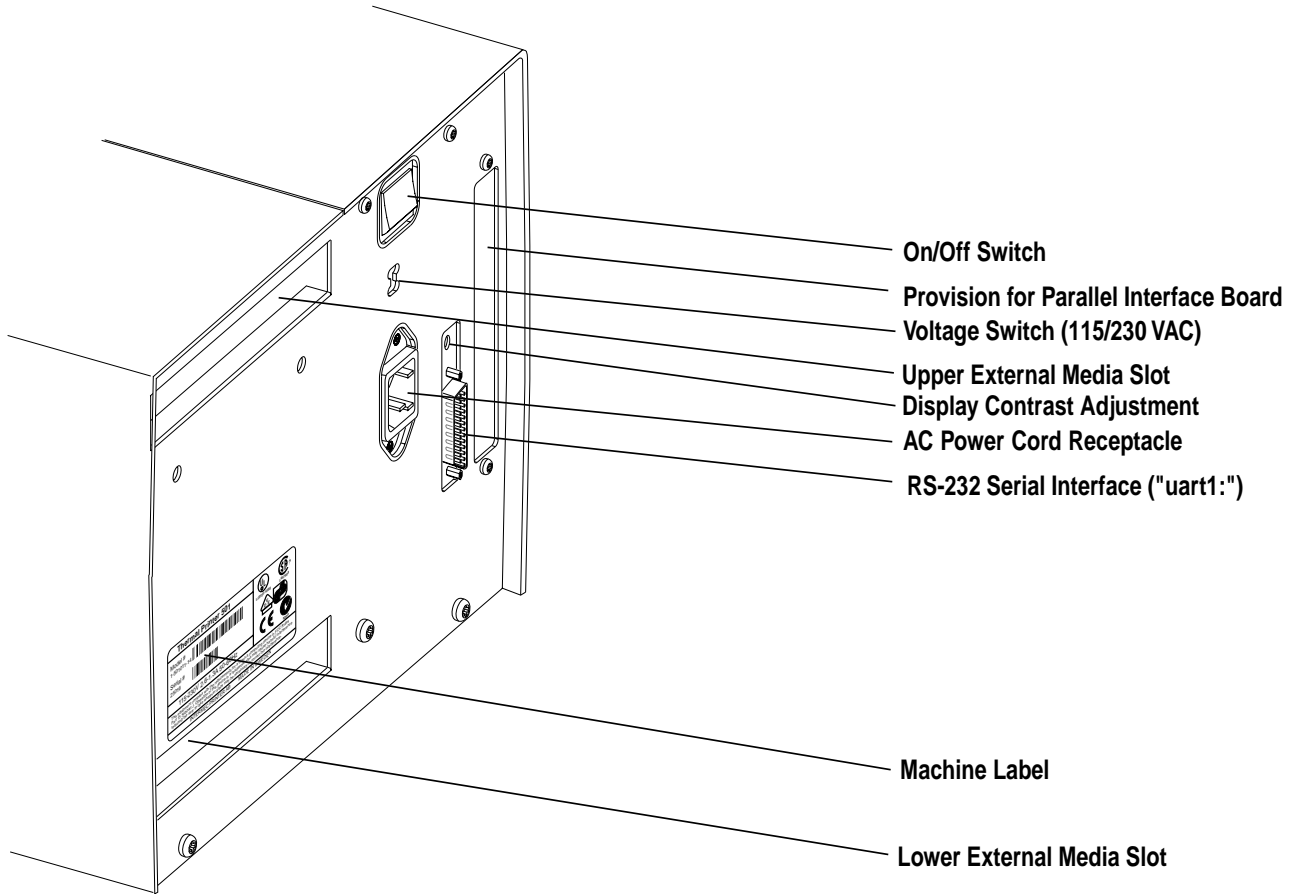

Media Compartment

The media compartment becomes accessible when the right-hand door and the front door or the cutter are opened. Although the printer is operable when the doors are left opened or completely removed, you are strongly recommended to keep them closed during normal operation, so as to prevent the print mechanism and the media from being exposed to dust.

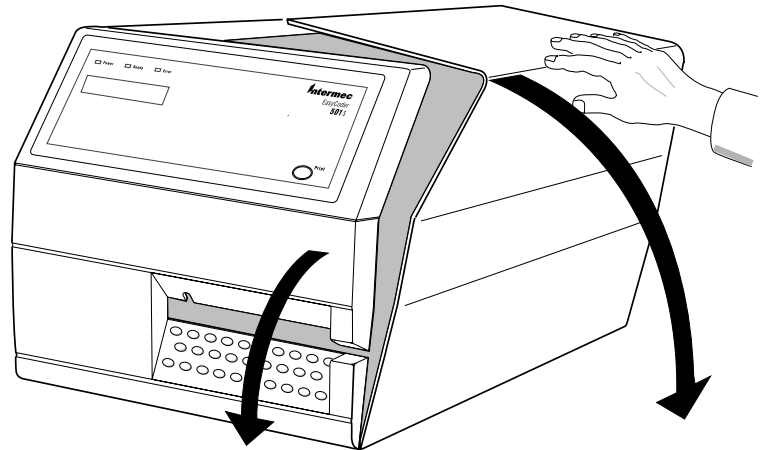

Media Com- partment, cont.

The illustration below shows an EasyCoder 501 S with some options installed. There are more options that are not illustrated here. Refer the Appendix 1 for complete lists of standard features and options for the EasyCoder 501 S.

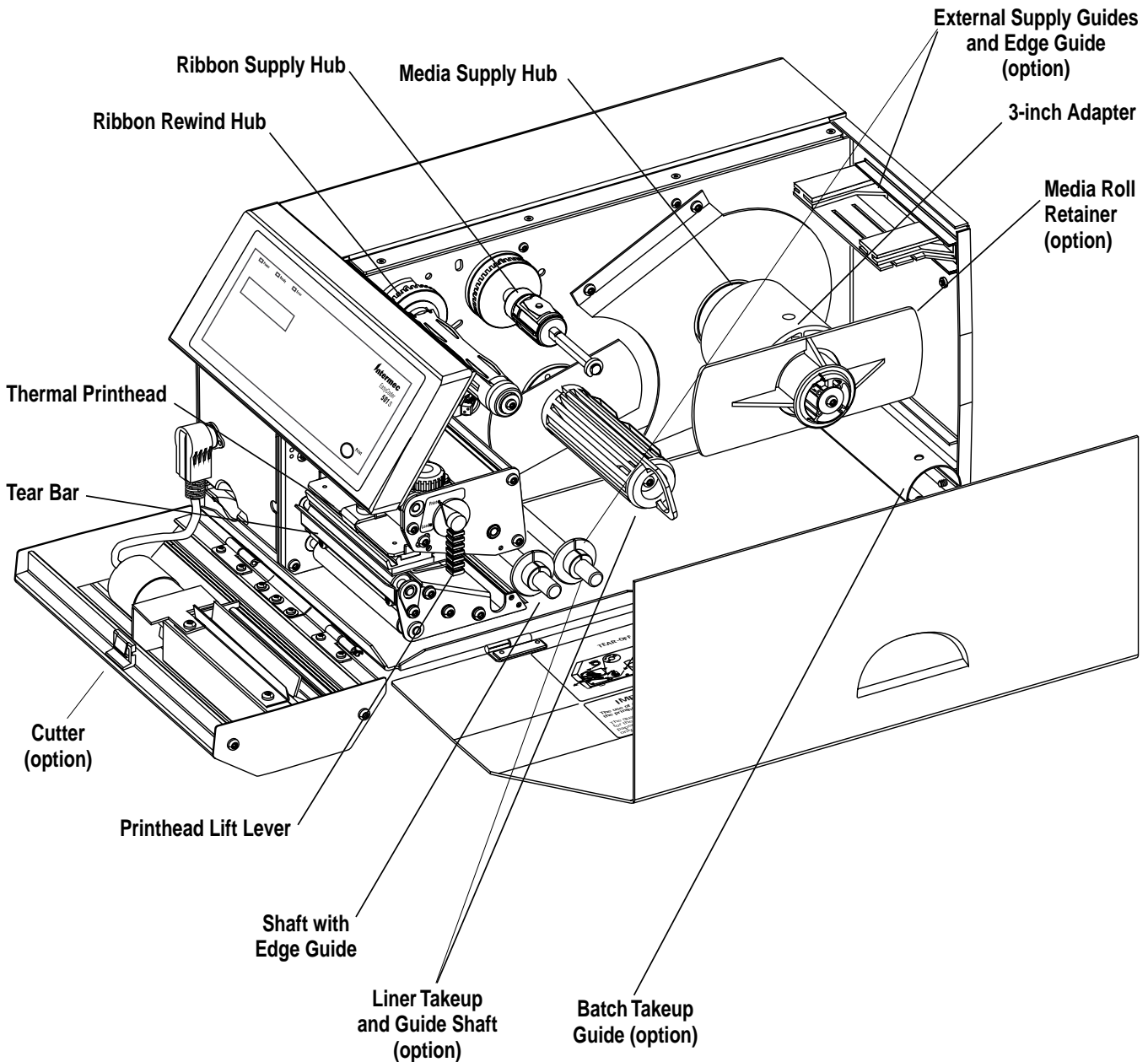

Print Unit

The print unit features a high performance 8 or 11.81 dots/mm (203.2 or 300 dots/inch) thermal printhead with quick-mount fittings to facilitate replacement.

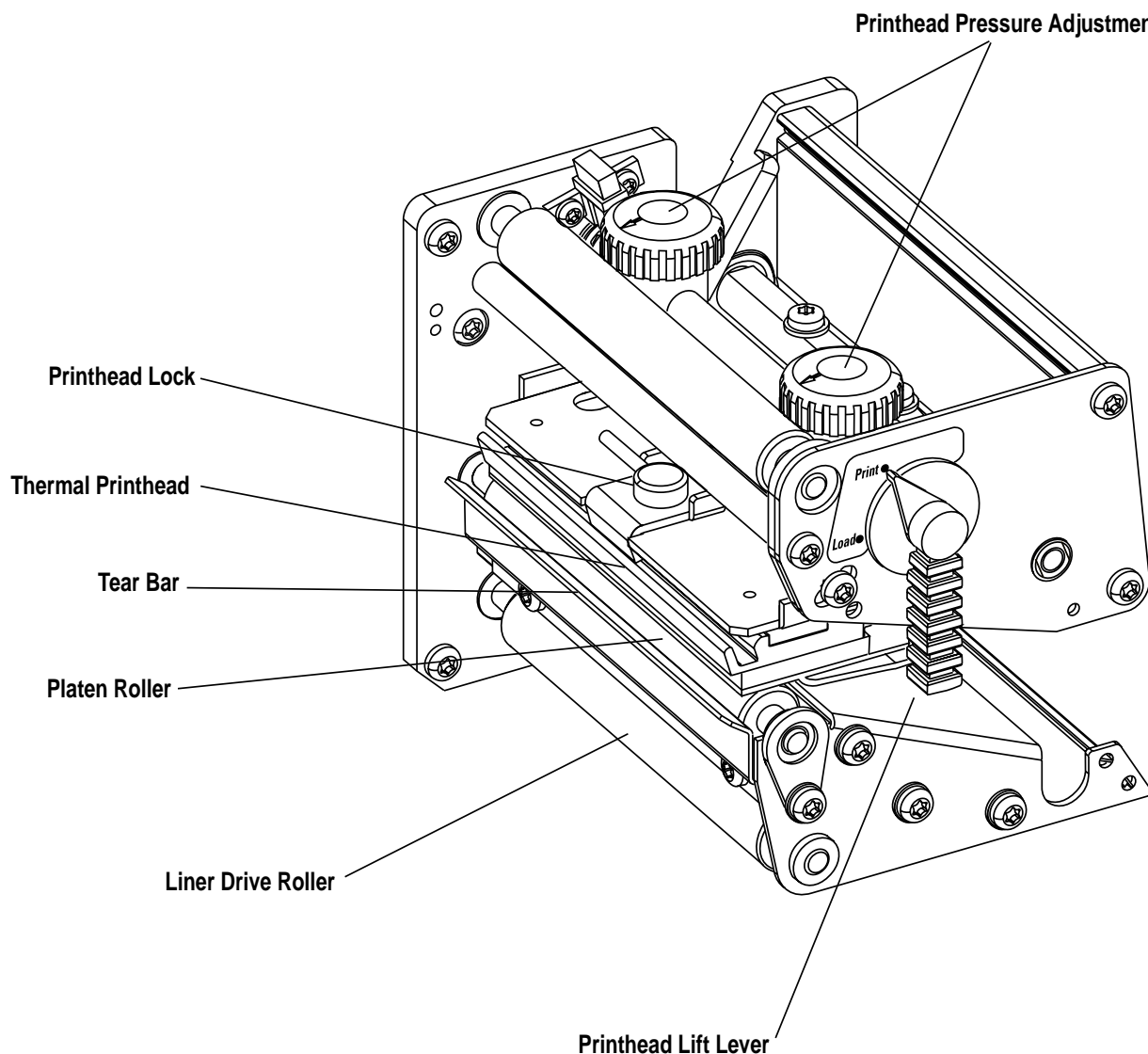

Connections

Power

- 1 Place the printer on a level surface, near an AC outlet. You should be able to easily access the printer to load media and to remove the printout.
- 2 Check that the printer is switched off.
- 3 Check that the printer is set for the correct voltage (115 or 230 VAC).
- 4 Connect the power cord between the receptacle on the rear plate and to the electrical outlet.

Computer

The EasyCoder 501 S is always fitted with one 25-pin D-style subminiature (DB25) female connector for the serial interface port "uart1:" (see Appendix 4).

- **Serial Interface "uart1:"**
(device name: "uart1:")

This interface is by default set for RS-232 communication, but can also be configured for either RS-422 or 20 mA current loop. Use the RS-232 interface with Intermec LabelShop or the Intermec InterDriver. Also use it with the Intermec Direct Protocol or the Intermec Fingerprint programming language because you can receive error messages from your printer. Before you can use the serial interface, you may need to set up the communication parameters, such as baud rate, parity, etc. as described in Chapter 7, "Setting Up the Printer."

- **Optional Parallel Interface Board**
(device name: "centronics:")

Refer to Appendix 4 and the separate documentation delivered with the board for connection instructions.

Switch off both the PC and the printer before connecting them together.

Controls and Indicators

Control Lamps

The EasyCoder 501 S has several ways of communicating directly with its operator: three control lamps, a display window, a membrane-switch keyboard, and a beeper.

The control lamps are colored LEDs (Light Emitting Diodes) and are used for the following purposes:

- *Power* (green) indicates when the power is on.
- *Ready* (green) indicates when the printer is ready for use.
- *Error* (red) indicates when some kind of error has occurred. If using a serial communication, an error message may be returned to the host computer.

Display

The display window contains an LCD (Liquid Crystal Display) and two lines of text, each with 16 characters. It guides the operator through the setup and indicates possible errors during printing.

The contrast of the display can be adjusted for the prevailing light conditions, as described in Chapter 13.

The Intermec Fingerprint programming language and the Intermec Direct Protocol allow custom-made messages to be composed and displayed according to the requirements of the application.

Keyboard

The keyboard is of the membrane-switch type and has a single print key.

In application programs created using the Intermec Fingerprint programming language, the key can be assigned to initiate various functions. An audible signal, which can be turned off if so desired, acknowledges that the key has been pressed.

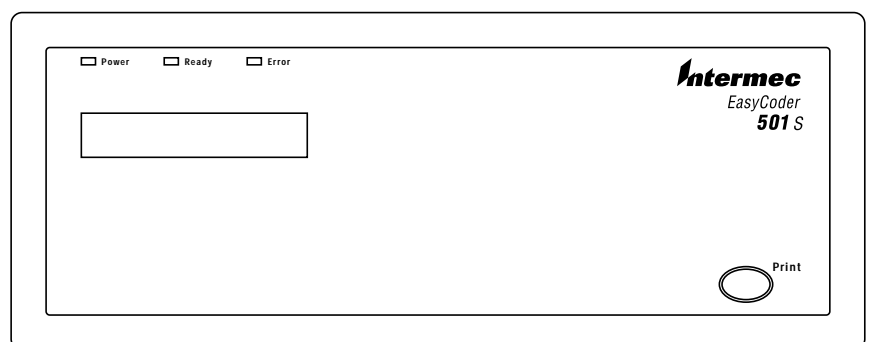

Controls and Indicators, cont.

Beeper

The beeper notifies the operator when an error has occurred and acknowledges that a key has been pressed. The Intermec Fingerprint programming language allows the key acknowledge signal to be turned off. The frequency and duration of signals can be specified. Thus, it is possible to create different signals for different conditions or even to make the printer play simple melodies!

Starting Up

Startup Files

At startup, the behaviour of the printer is decided by the possible existence of a startup (autoexec) file (that is, a program that automatically starts running when the printer is switched on) somewhere in the printer's memory. There are three major possibilities:

- A** The printer is fitted with the Intermec Shell Standard file-managing program, which allows the operator to choose between a variety of applications and functions.
- B** The printer is fitted with no startup file at all.
- C** The printer is fitted with a custom-made application program that is design to perform a specific task, for example to print tickets, baggage tags, or product labels for a certain company.

There can be one startup file stored in each of the following parts of the printer's memory: RAM, ROM, and memory cards (option). If there are startup files stored in more than one place, they will be used with the following priority:

1. Dos-formatted memory cards (SRAM).
2. Printer's RAM memory.
3. Non DOS-formatted memory cards (SRAM or OTPROM).
4. Printer's ROM memory, for example the configuration EPROMs.

This implies that if you have a startup file stored in the configuration EPROMs and insert a memory card in the optional memory card adapter (see Chapter 9) with another startup file before you switch on the printer, the startup file of the memory card will be used.

Abbreviations:

<i>EPROM:</i>	<i>Erasable Programmable Read-Only Memory</i>
<i>OTPROM:</i>	<i>One-Time Programmable Read-Only Memory</i>
<i>RAM:</i>	<i>Random Access Memory</i>
<i>ROM:</i>	<i>Read-Only Memory</i>
<i>SRAM:</i>	<i>Static Random Access Memory</i>

Switching On the Printer

Do not start the printer before you have made the necessary connections, inserted any memory card you want to use, and checked that the printhead is lowered and an optional cutter is in closed position.

Switch on the power by means of the On/Off switch on the rear plate. The “Power” LED control lamp on the front panel lights up when the power is on. Wait for a few moments, while the printer loads the program and runs some self-diagnostic tests. If the printer is fitted with a cutter, it will rotate to home position. Finally, some kind of message will appear in the display window.

After starting up the printer for the first time, keep the power on overnight to charge the memory backup battery.

Display Messages at Startup

The type of startup file running in the printer is indicated by the message shown in the display window **immediately** after startup.

Intermec Shell Standard Startup Program

```
PRINT=SHELL
5 sec.   v.4.01
4 sec.   v.4.01
3 sec.   v.4.01
2 sec.   v.4.01
1 sec.   v.4.01
```

Refer to Chapter 8 for more information on Intermec Shell. The digits in the lower right corner of the display indicate the version of Intermec Shell.

No Intermec Shell Program Installed (non-standard printers)

```
Fingerprint
6.14
```

Refer to the documentation of the corresponding version of Intermec Fingerprint for further information.

Custom-Made Application Program (non-standard printers)

Any other display messages than those illustrated above indicates that the printer is running some custom-made, non-standard application program, or that some error has occurred.

Media Load

Tear-Off (Straight-through)

The EasyCoder 501 S can print on labels, tickets, tags, and continuous stock in various forms. This section describes the case when the media is to be torn off manually against the printer's tear bar. This method is also known as "straight-through printing."

Tear-off can be used for:

- Non-adhesive continuous stock
- Self-adhesive continuous stock with liner
- Linerless self-adhesive continuous stock
- Self-adhesive labels with liner
- Tickets with gaps, with or without perforations
- Tickets with black marks, with or without perforations

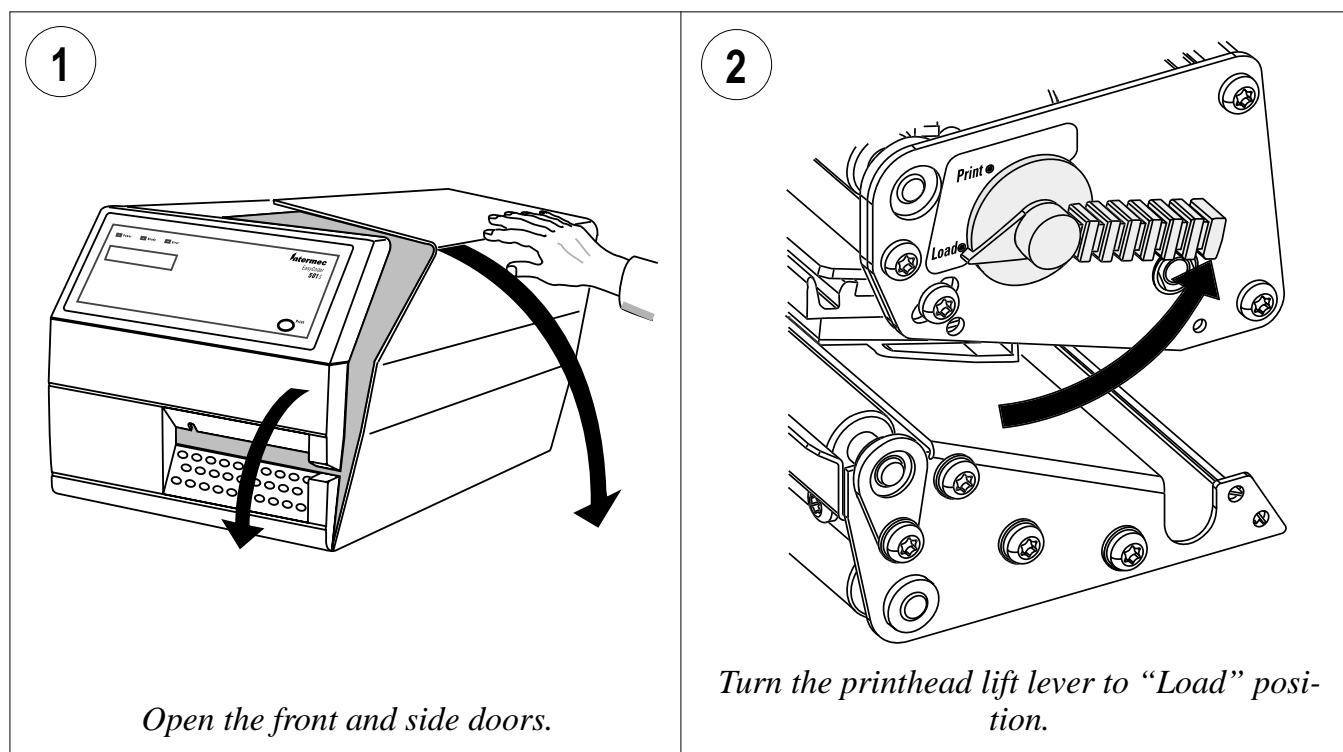

Tear-Off, cont.

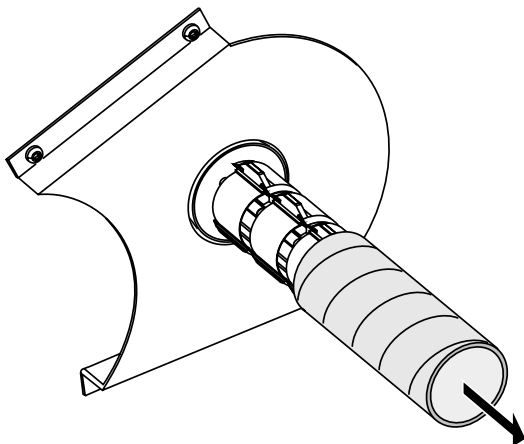
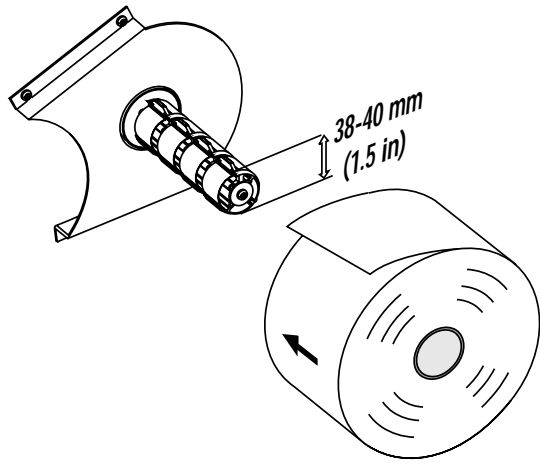
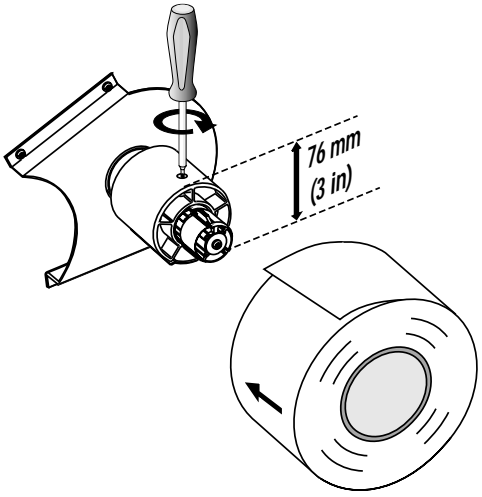
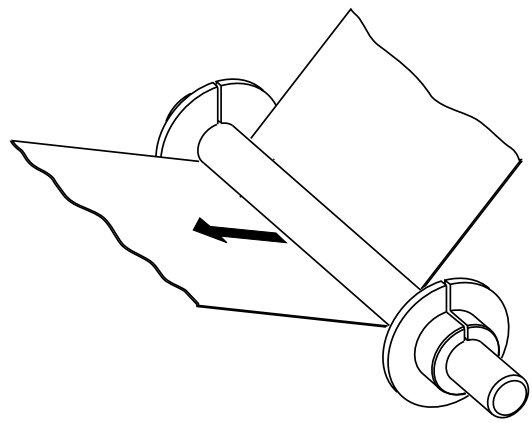
<p>3</p>  <p><i>Remove any empty core from the media supply hub.</i></p>	<p>4a</p>  <p><i>Fit a new roll of media on the supply hub and push the roll inwards as far as it will go.</i></p>
<p>4b</p>  <p><i>In case of a media roll with a 76.2 mm (3 inches) core, first fit the adapter on the media supply hub.</i></p>	<p>5</p>  <p><i>Route the media underneath the guide shaft behind the print mechanism.</i></p>

Tear-Off, cont.

6

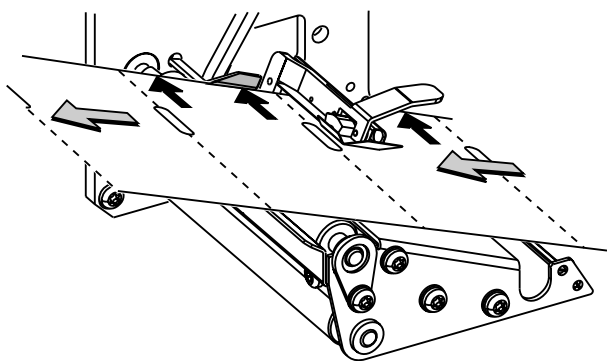

Route the media under the guide plate of the label stop sensor and push it inwards towards the center section as far as it will go.

7

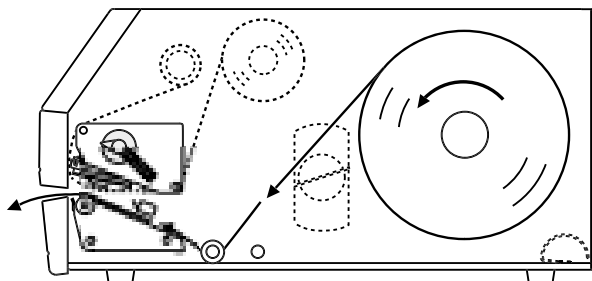

This diagram shows the media path.

8

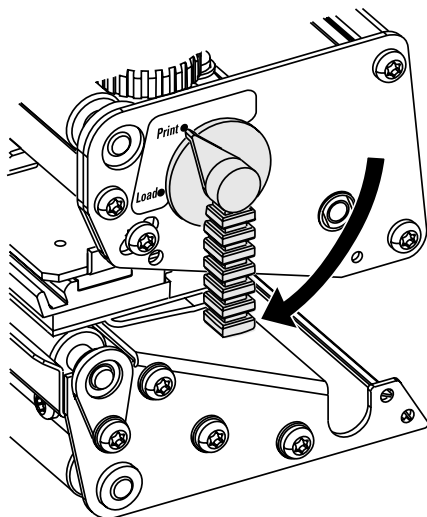

Turn the printhead lift lever to "Print" position.

9

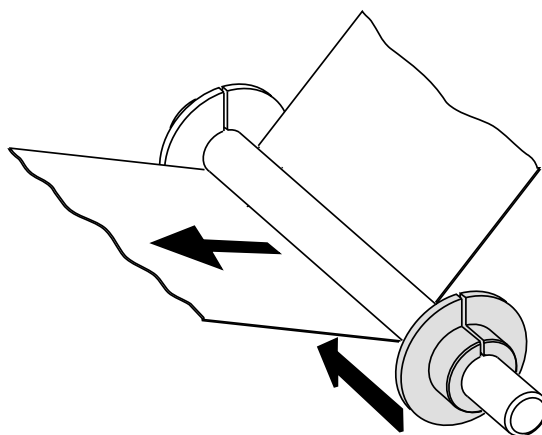

Adjust the green edge guide so the media is guided with a minimum of play.

Tear-Off, cont.

10

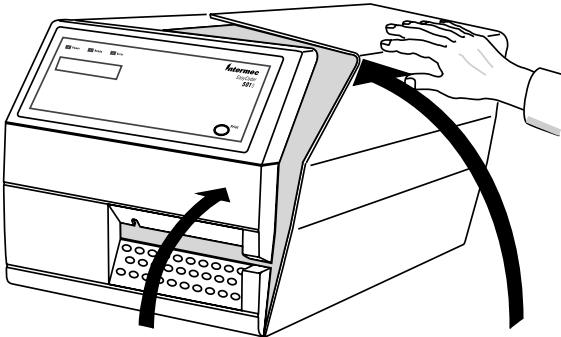

Close the front and side doors.

11

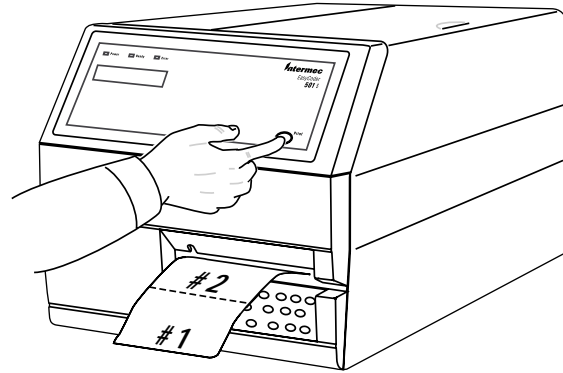

*Feed out two blank copies by pressing the **Print** key twice.*

12

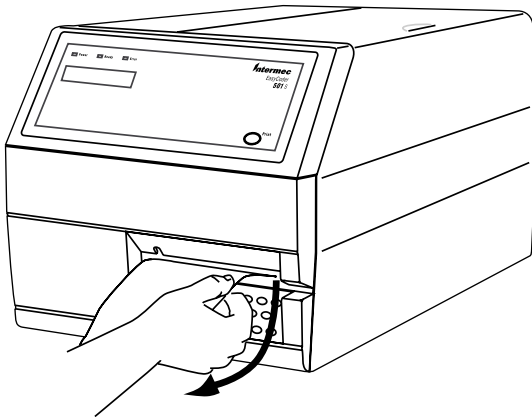

Tear of the media by pulling it downwards against the tear bar.

Cut-Off

Warning!

The cutting edge will rotate when the power is switched on and when the printer is rebooted. Always switch off the power before opening the cutter unit.

The EasyCoder 501 S printers can print on labels, tickets, tags, and continuous stock in various forms. This section describes the case when the media is to be cut off by an optional automatic cutter.

Cut-off can be used for:

- Non-adhesive continuous stock
- Self-adhesive continuous stock with liner
- Self-adhesive labels with liner (cut only liner between labels)

The cutter is designed to cut through paper-based media with a thickness of max 175 μm , which roughly corresponds to a paper weight of 175 grams/m² (basis weight 120 lb). The cutter should not be used to cut through labels, because the adhesive will stick to the shears, which can damage the cutter.

The cutter is held by a snap-lock and can be tilted forward to facilitate media load.

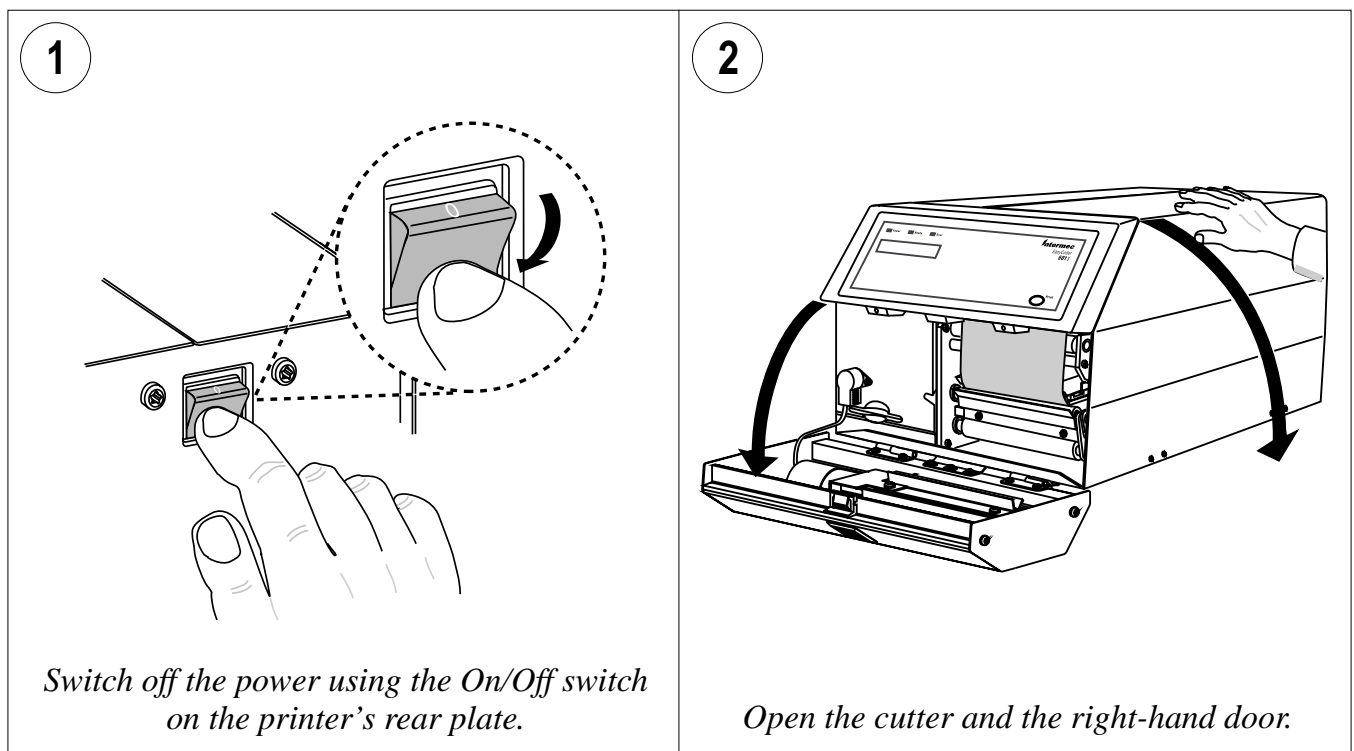

Cut-Off, cont.

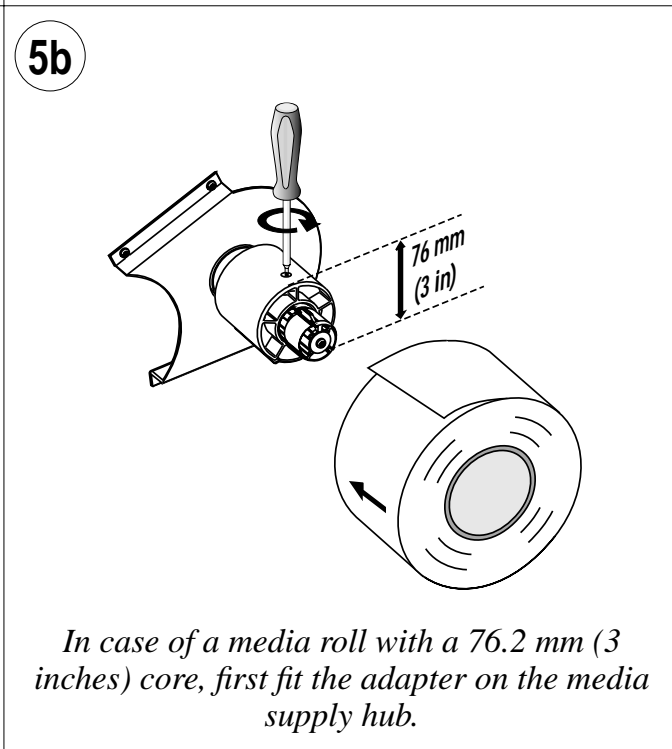
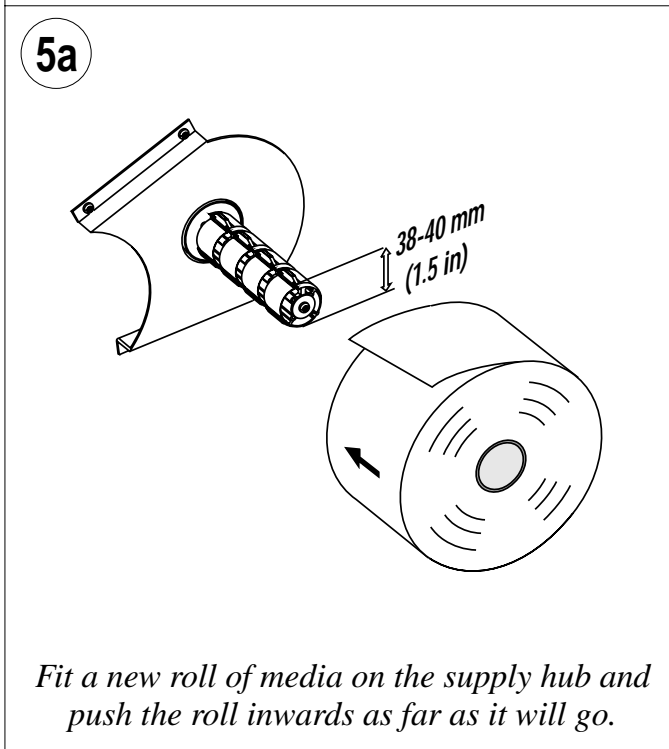
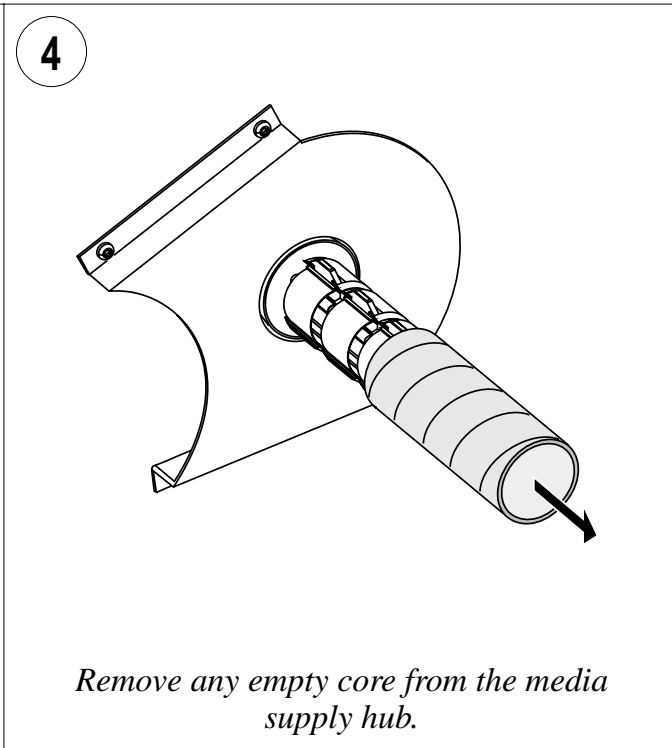
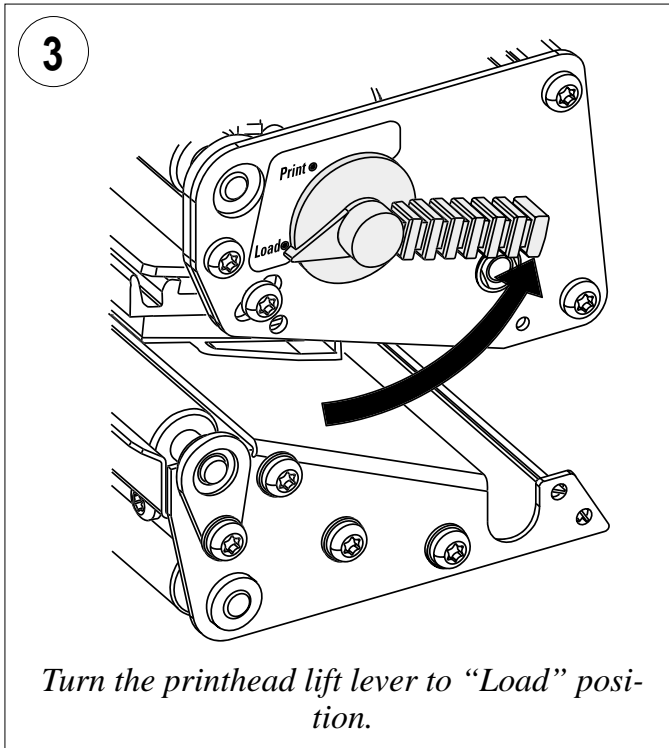

Cut-Off, cont.

6

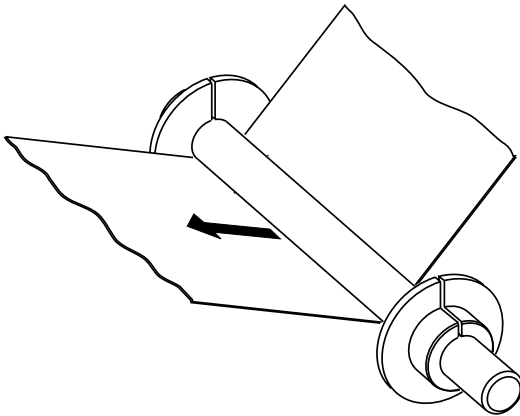

Route the media underneath the guide shaft behind the print mechanism.

7

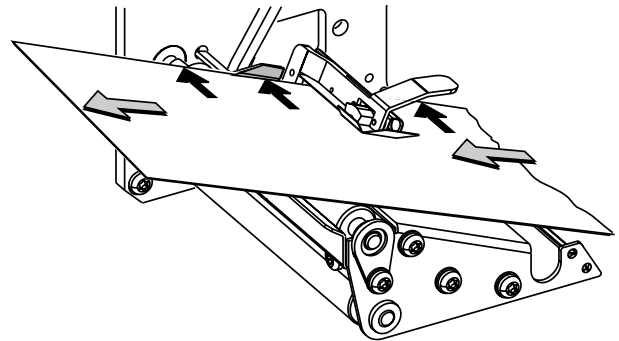

Route the media under the guide plate of the label stop sensor and push it inwards towards the center section as far as it will go.

8

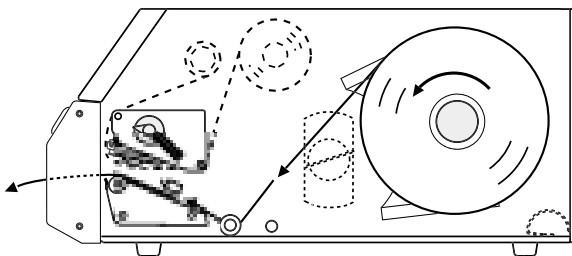

This diagram shows the media path.

9

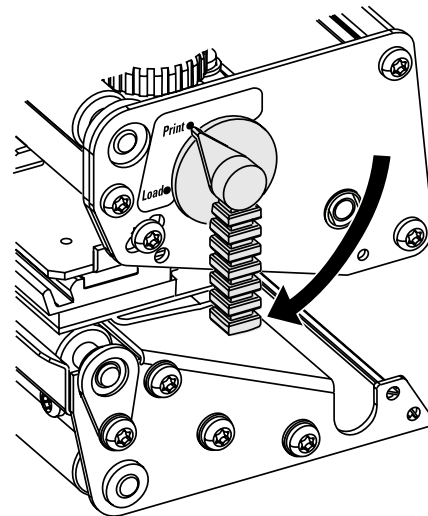

Turn the printhead lift lever to "Print" position.

Cut-Off, cont.

10

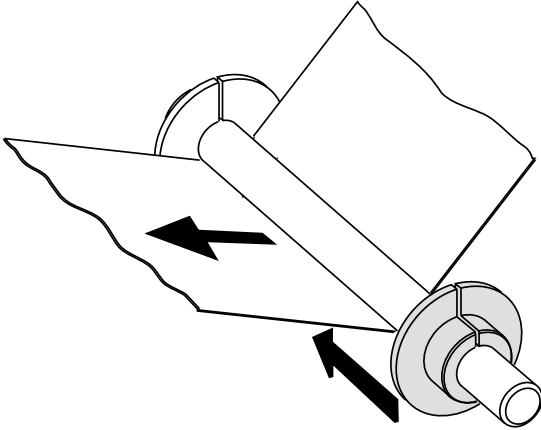

Adjust the green edge guide so the media is guided with a minimum of play.

11

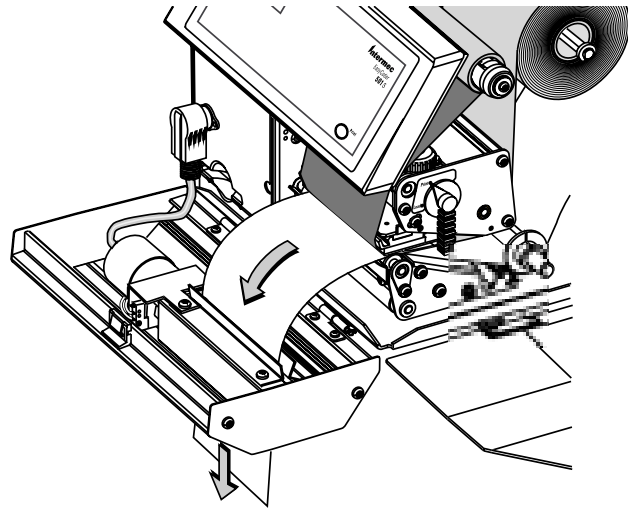

Route the media through the cutter between the two guide plates.

12

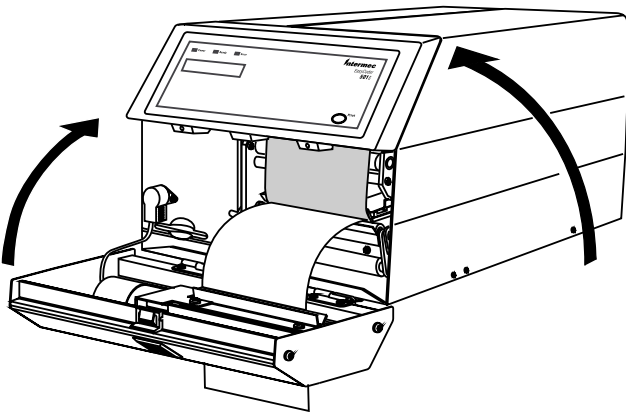

Close the cutter while pulling at the end of the media. Close the right-hand door and switch on the power.

13

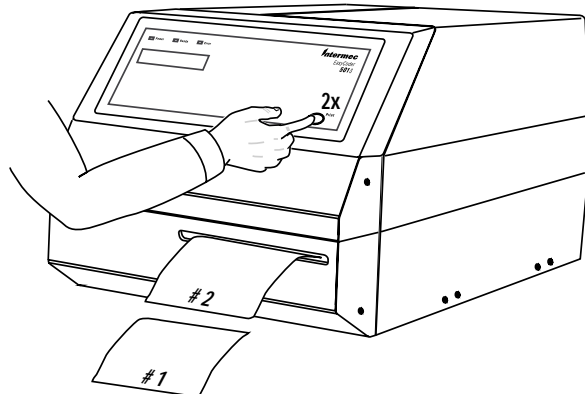

*Feed out and cut two blank copies by pressing the **Print** key twice.*

Peel-Off (Self-strip)

The EasyCoder 501 S printers can print on labels, tickets, tags, and continuous stock in various forms. This section describes the case when self-adhesive labels are separated from the liner immediately after printing. The liner is then wound up on an optional integral liner takeup hub. This is also known as “Self-strip” operation.

Peel-off can only be used for:

- Self-adhesive labels with liner

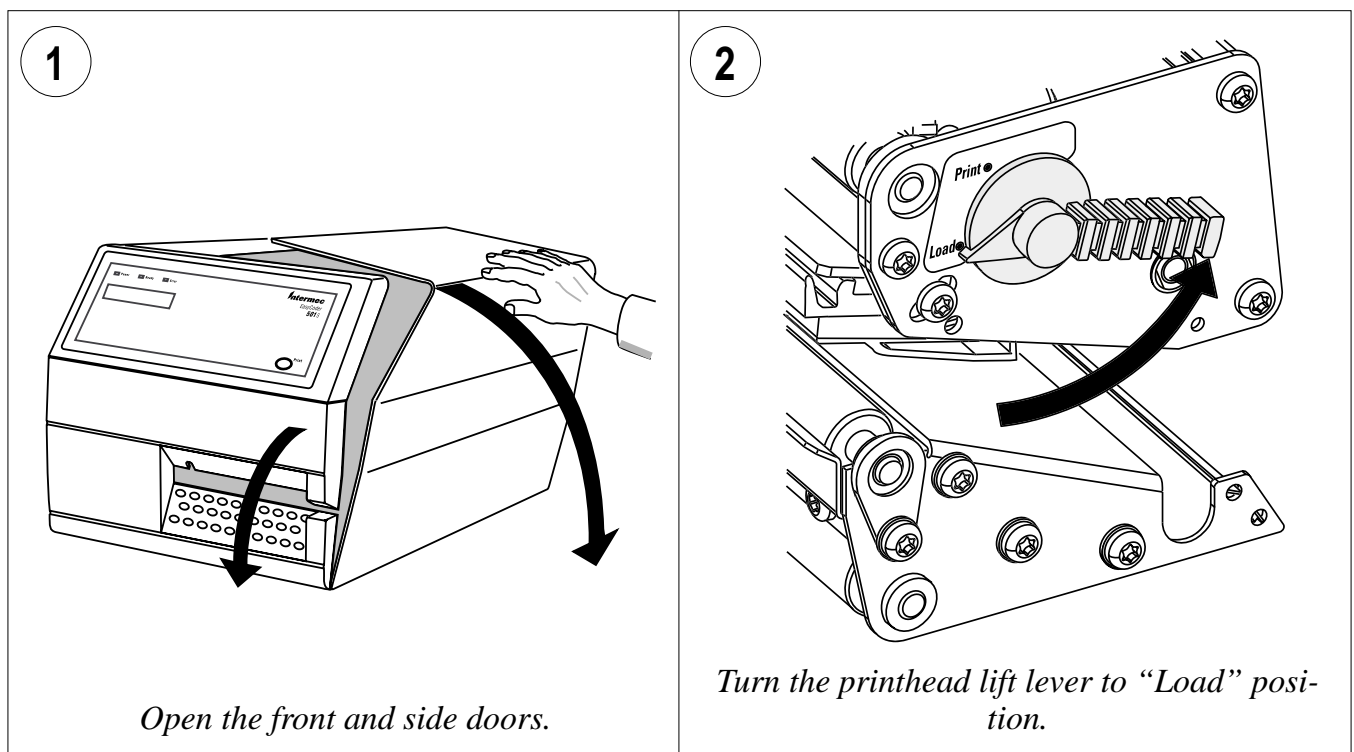

Peel-Off, cont.

3

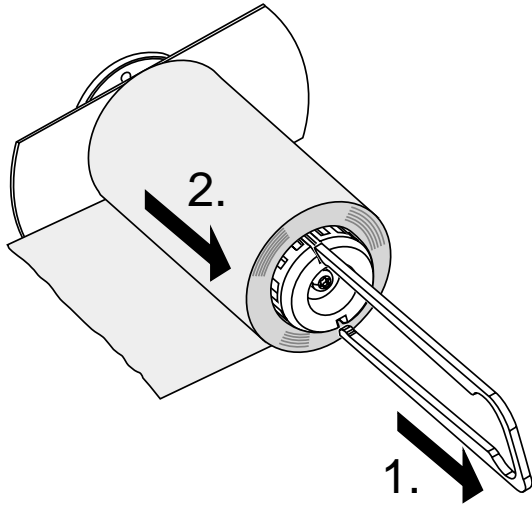

Pull out the green clip (1) on the liner takeup hub and dispose of all wound-up liner (2).

4

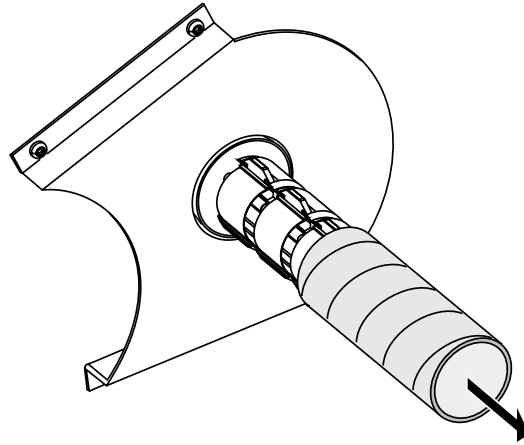

Remove any empty core from the media supply hub.

5a

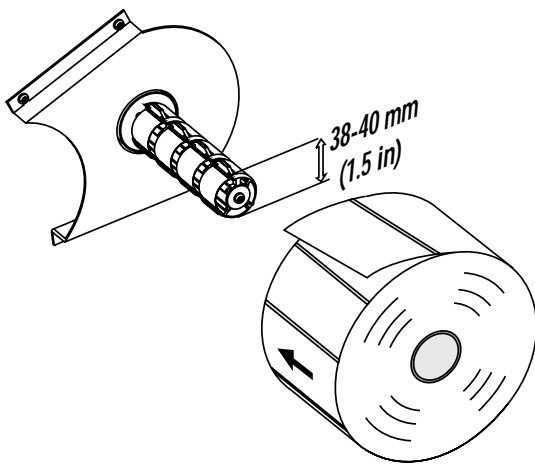

Fit a new roll of labels on the supply hub and push the roll inwards as far as it will go.

5b

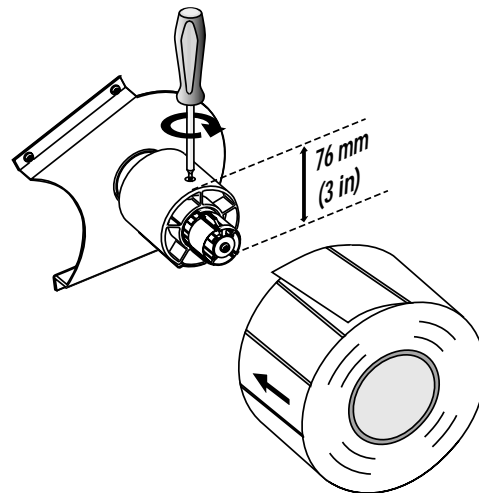

In case of a label roll with a 76.2 mm (3 inches) core, first fit the adapter on the media supply hub.

Peel-Off, cont.

6

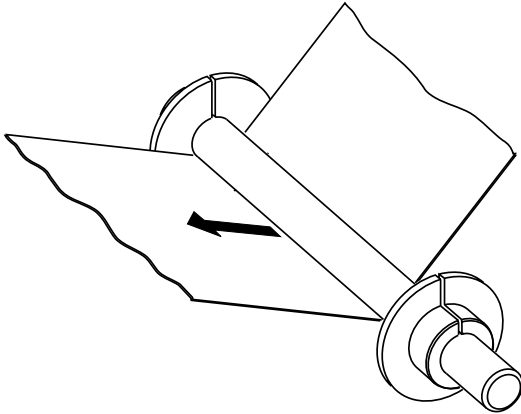

Route the media underneath the guide shaft behind the print mechanism.

7

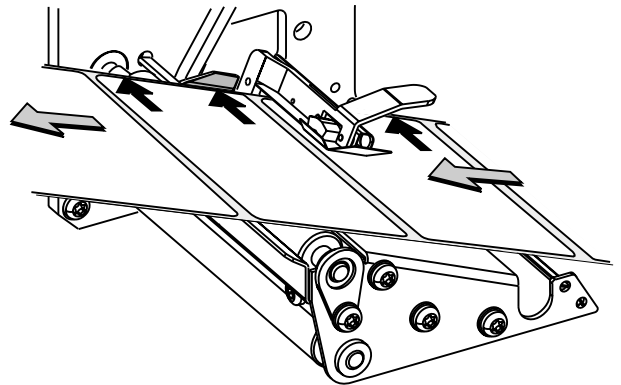

Route the media under the guide plate of the label stop sensor and push it inwards towards the center section as far as it will go.

8

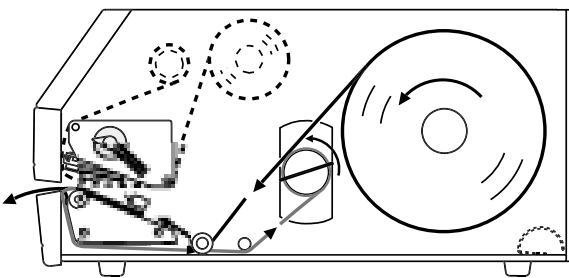

This diagram shows the path of the labels and the liner.

9

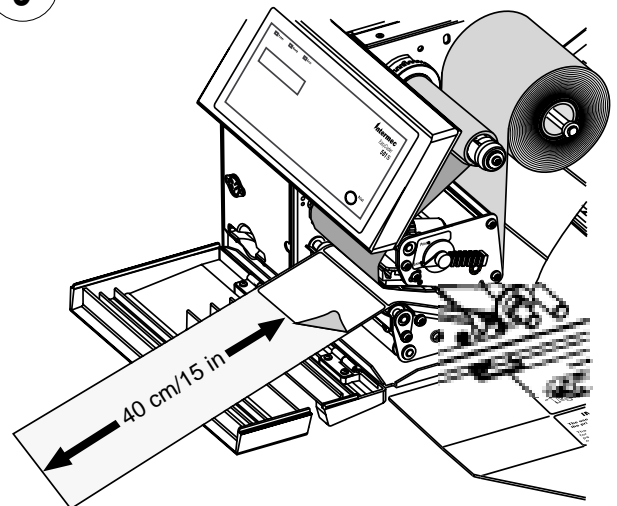

Pull out approximately 40 cm (15 inches) of labels and peel off the labels manually from the liner.

Peel-Off, cont.

10

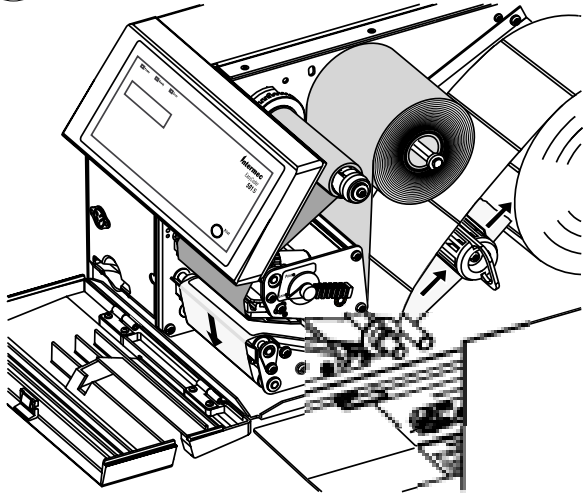

Route the liner around the platen roller and the tear bar, then rearwards under the print unit.

11

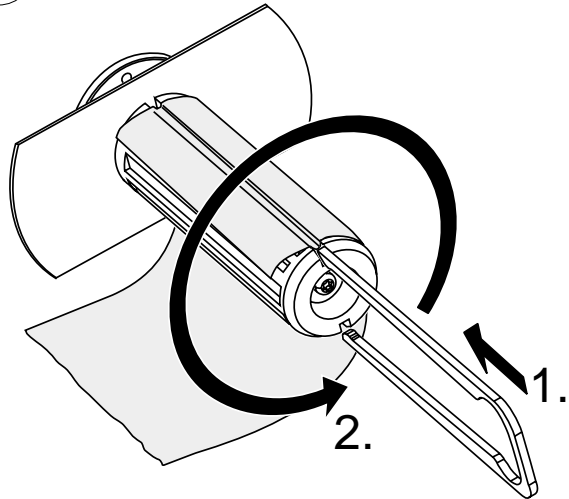

Secure the liner to the takeup hub with the clip (1) and wind up some of the liner so it becomes tight (2).

12

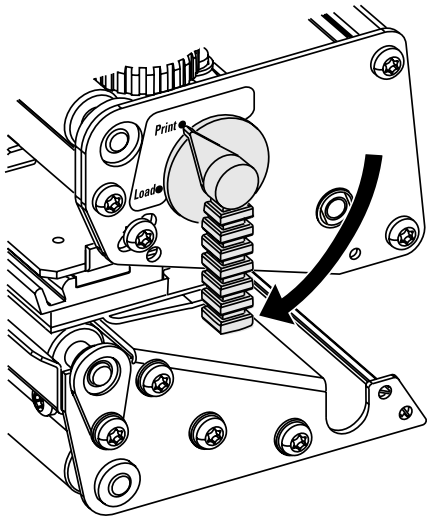

Turn the printhead lift lever to “Print” position.

13

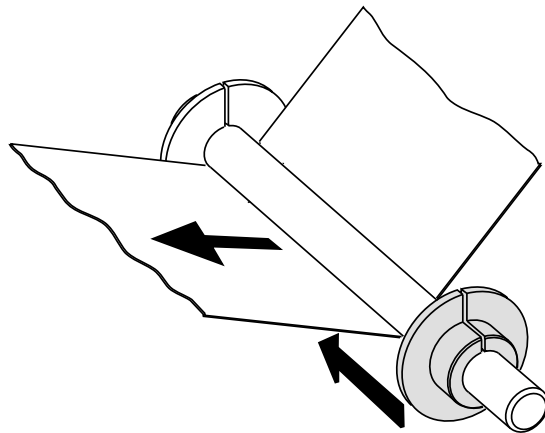

Adjust the green edge guide so the media is guided with a minimum of play.

Peel-Off, cont.

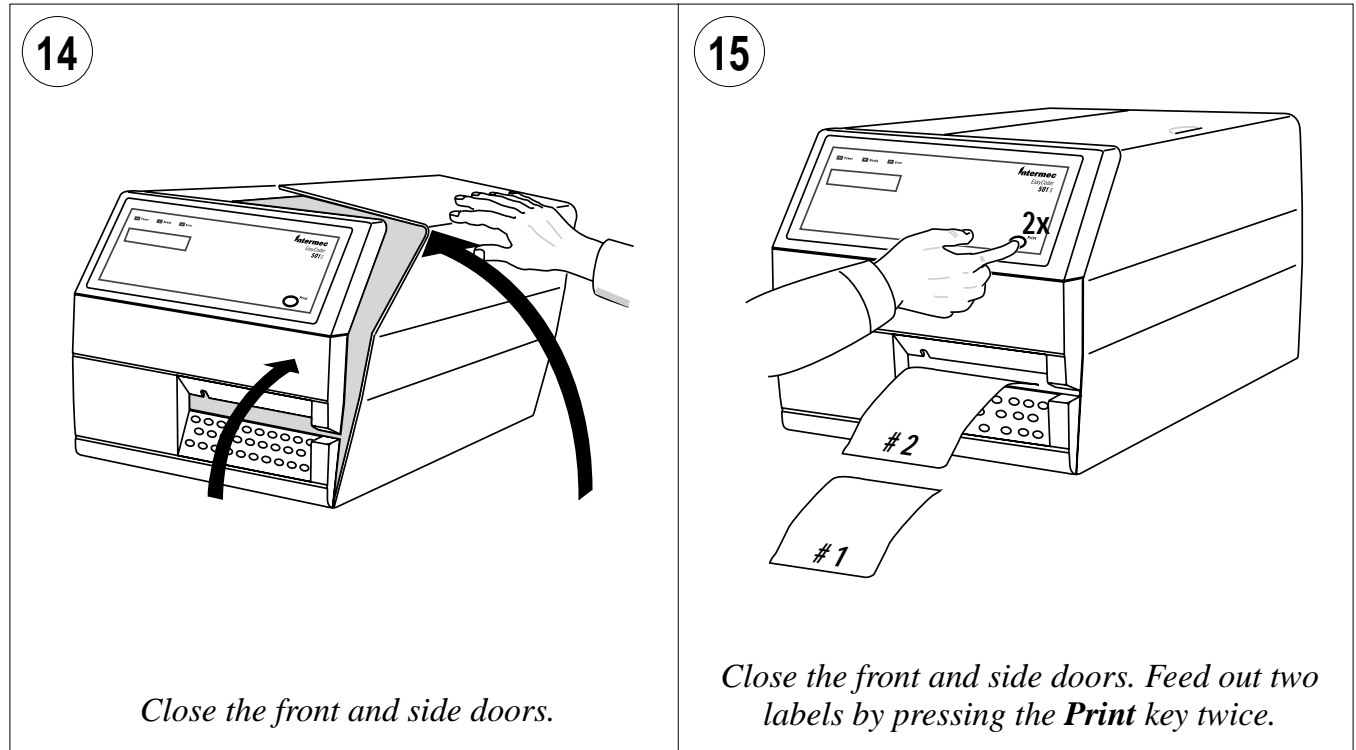

Internal Batch Takeup

The EasyCoder 501 S printers can print on labels, tickets, tags, and continuous stock in various forms. This chapter describes the case when printed labels fitted on liner (backing paper) or pre-perforated tickets and tags are wound up inside the printer. The roll of printed labels, tickets, or tags can then be removed and be handled manually. This requires an optional internal liner takeup unit and a batch takeup guide.

The takeup hub can accommodate $\frac{1}{4}$ to $\frac{1}{3}$ of a full-size media roll.

Internal batch takeup can be used for:

- Self-adhesive labels fitted on liner
- Preperforated tickets with gaps
- Preperforated tickets with marks

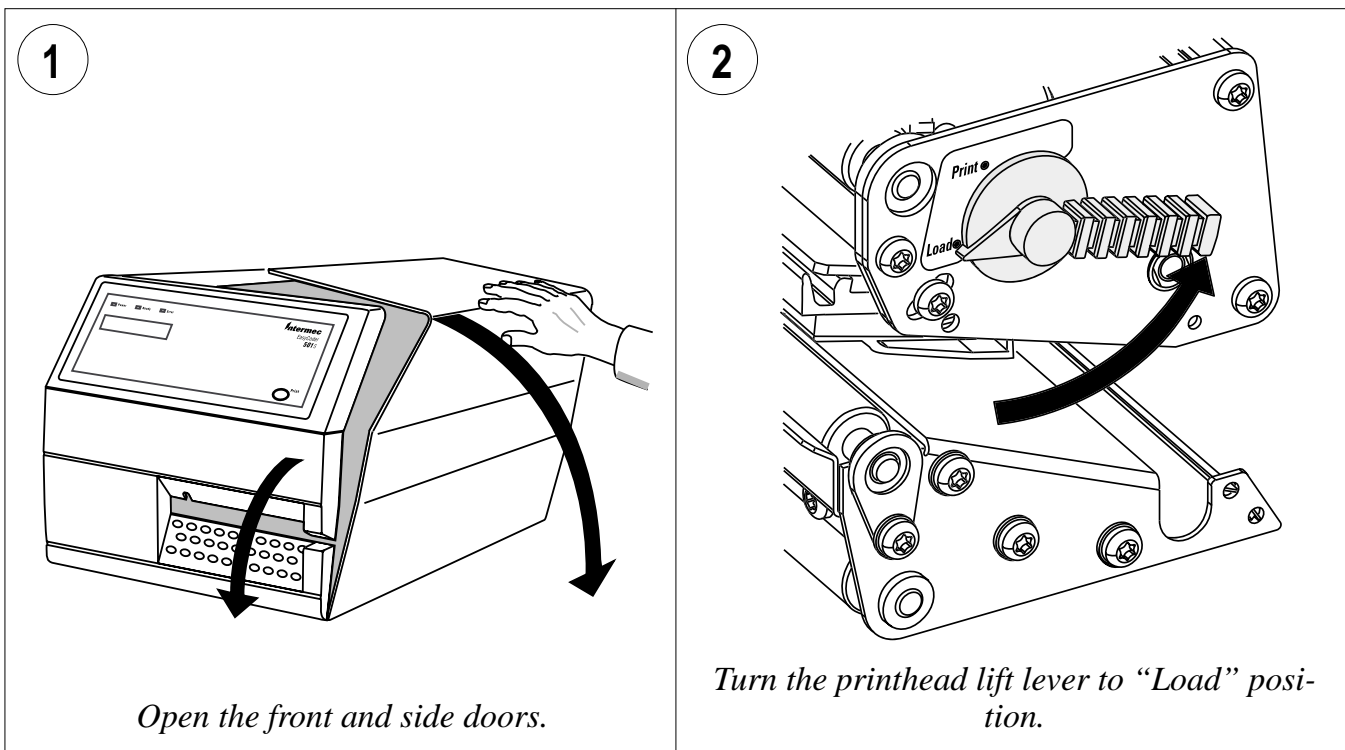

Internal Batch Takeup, cont.

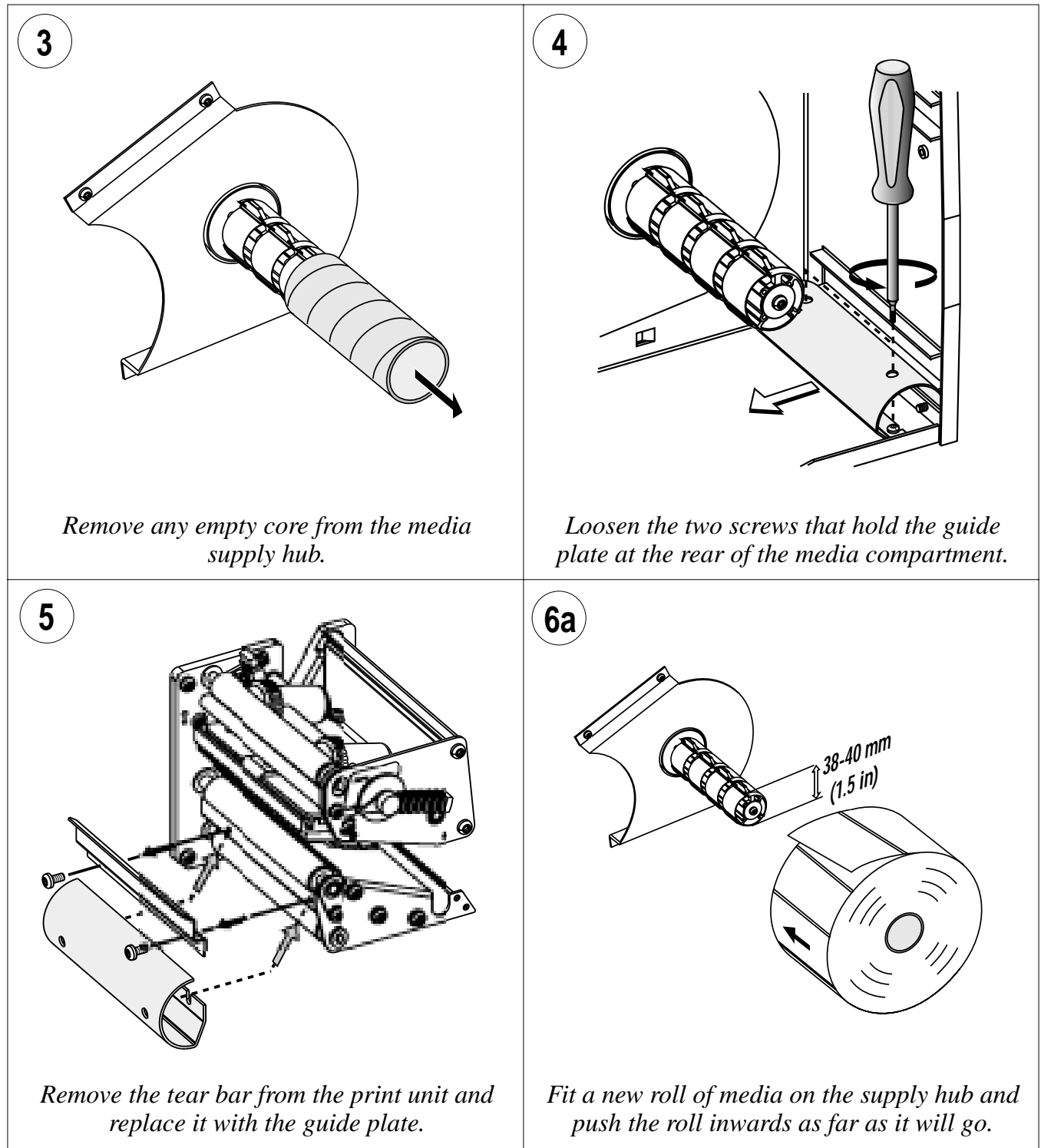

Internal Batch Takeup, cont.

6b

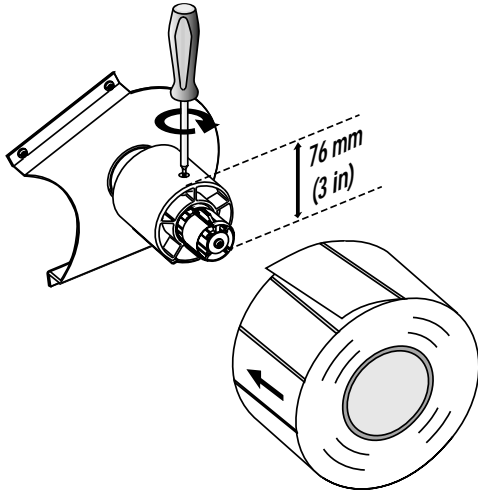

In case of a media roll with a 76.2 mm (3 inches) core, first fit the adapter on the media supply hub.

7

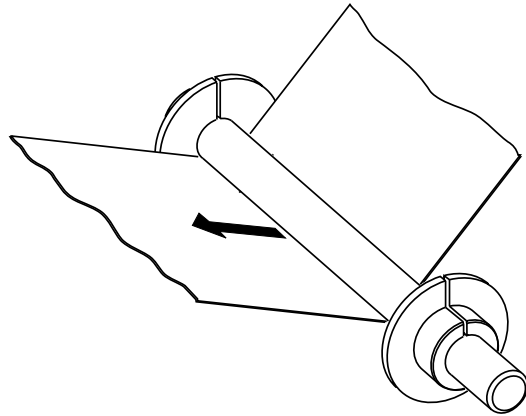

Route the media underneath the guide shaft behind the print mechanism.

8

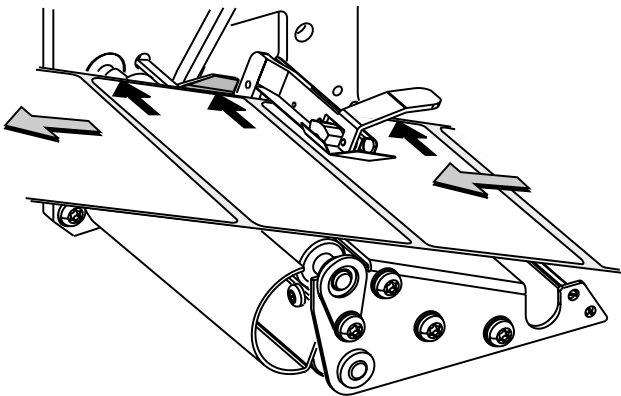

Route the media under the guide plate of the label stop sensor and push it inwards towards the center section as far as it will go.

9

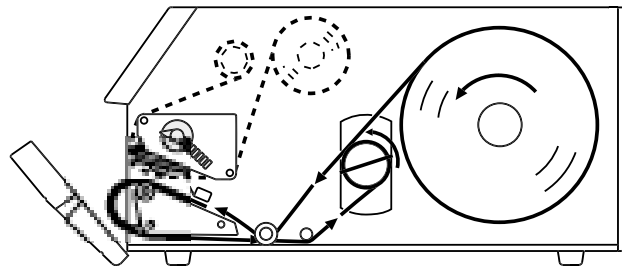

This diagram shows the path of the media.

Internal Batch Takeup, cont.

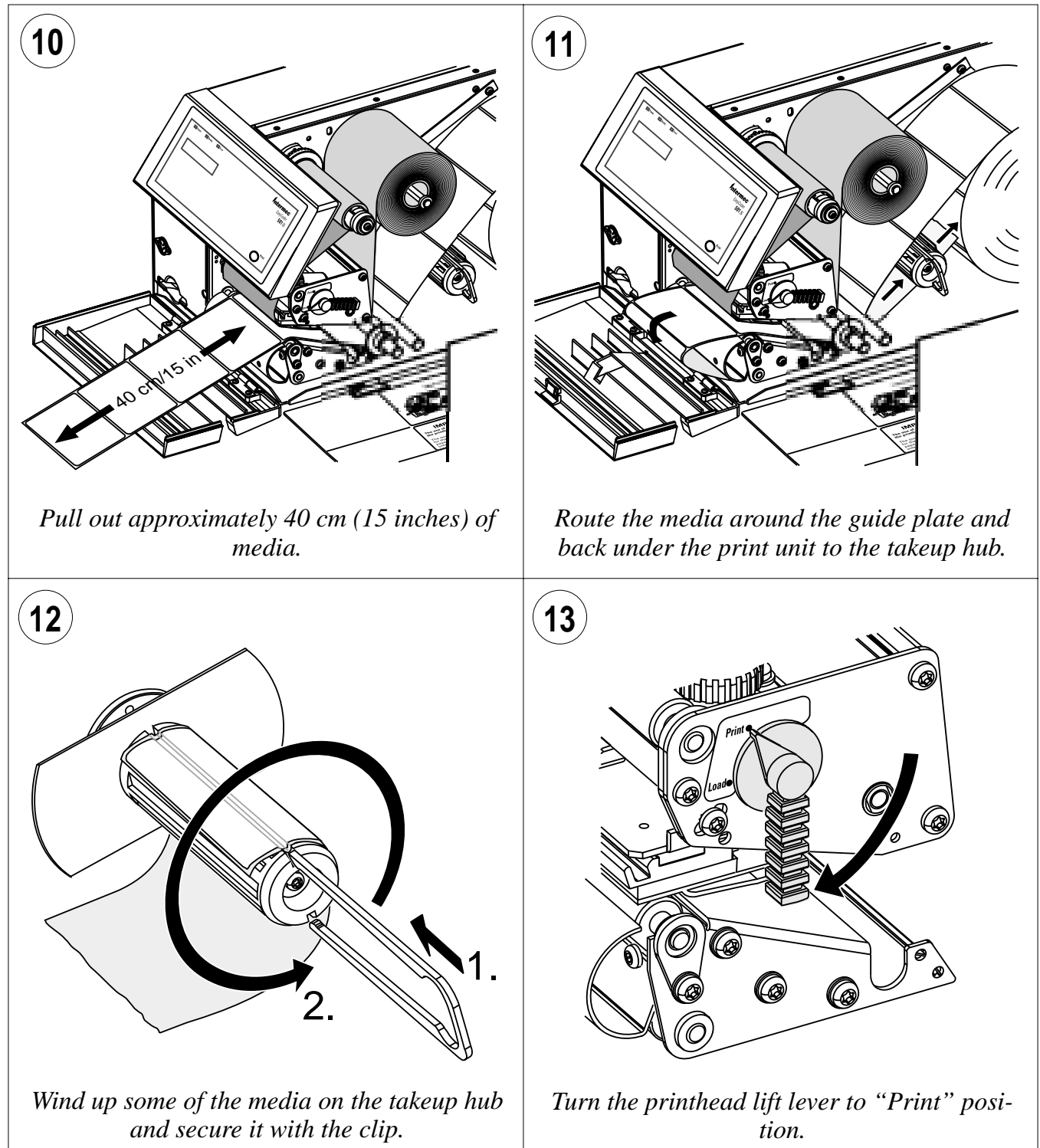

Internal Batch Takeup, cont.

14

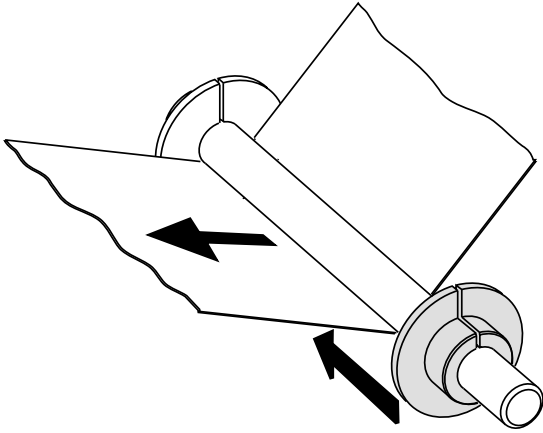

Adjust the green edge guide so the media is guided with a minimum of play.

15

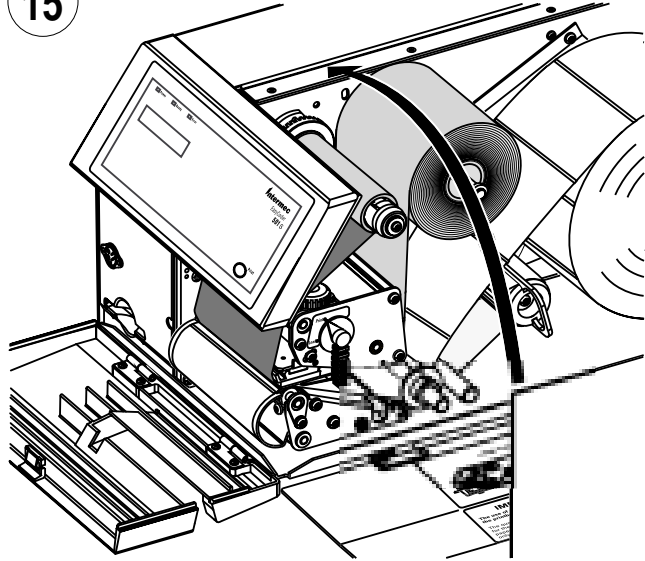

Close the right-hand door but keep the front door open.

16

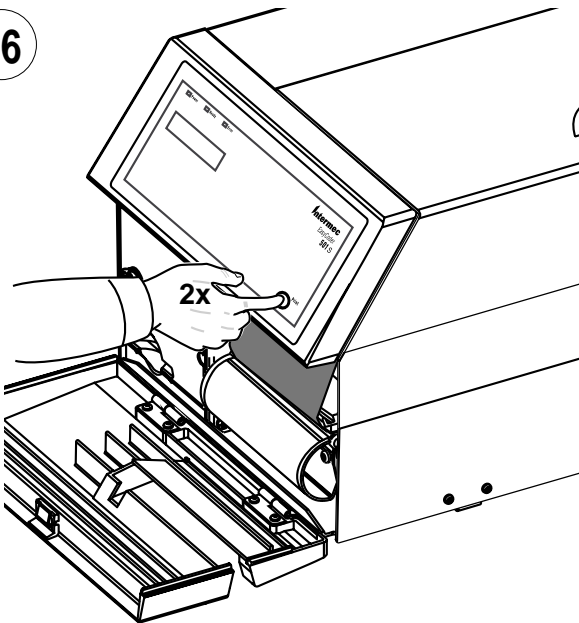

*Feed two blank copies by pressing the **Print** key.*

External Supply

The EasyCoder 501 S can print on labels, tickets, tags, and continuous stock in various forms. This chapter describes the case when an external media supply is used, for example a stack of fan-fold tickets or an external media roll.

It is possible to simply let the media enter the printer through either of the two slots in the rear plate. However, we recommend to fit the optional Intermec Fan-Fold Kit, which provides better guidance of the media using adjustable guides. The kit can be fitted to either the upper or the lower slot in the rear plate.

When using an external media supply, take care to protect the media from dust, dirt, and other foreign particles, that can impair the printout quality or cause unnecessary wear to the printhead.

Depending on brand and quality, all direct thermal media are more or less sensitive to heat, direct sunlight, moisture, oil, plasticizers, fat, and other substances. You should protect it accordingly.

External supply can be used for:

- Tear-off operation
- Cut-off operation
- Peel-off operation (upper slot only)
- Internal batch takeup operation

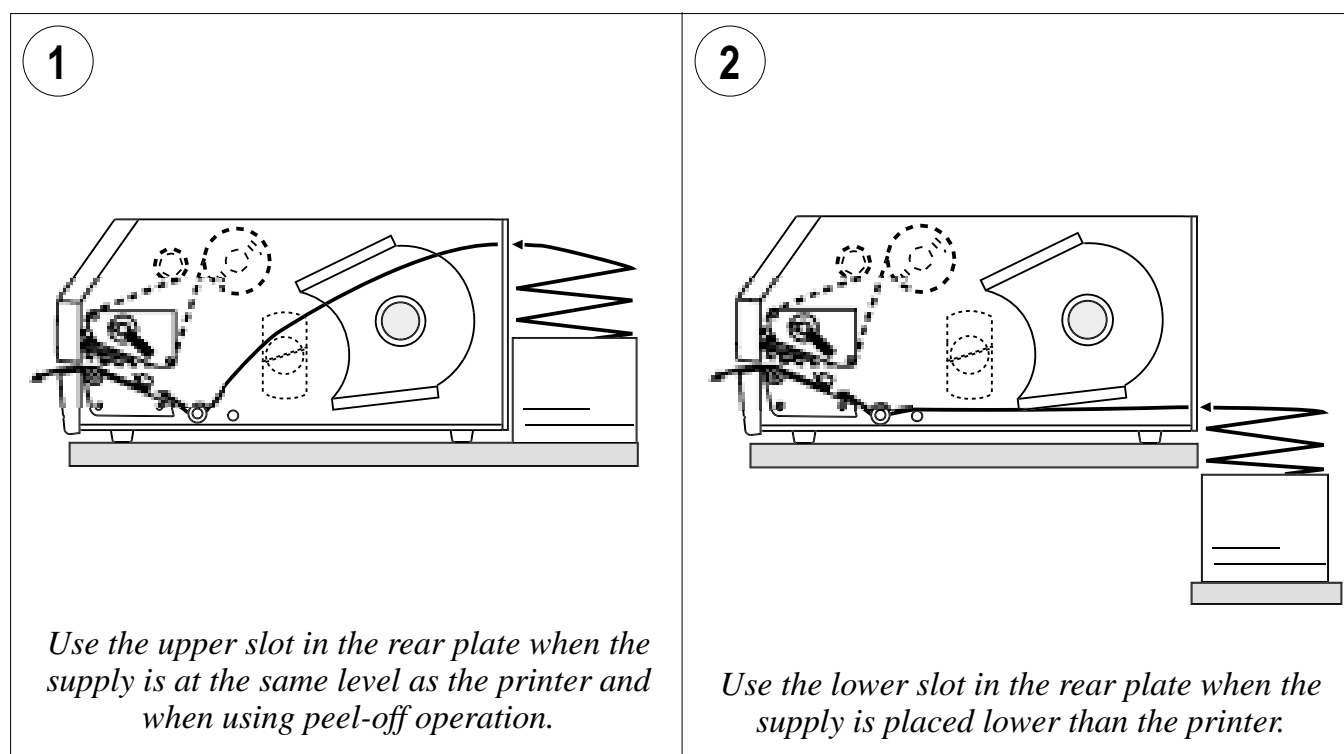

External Supply, cont.

3

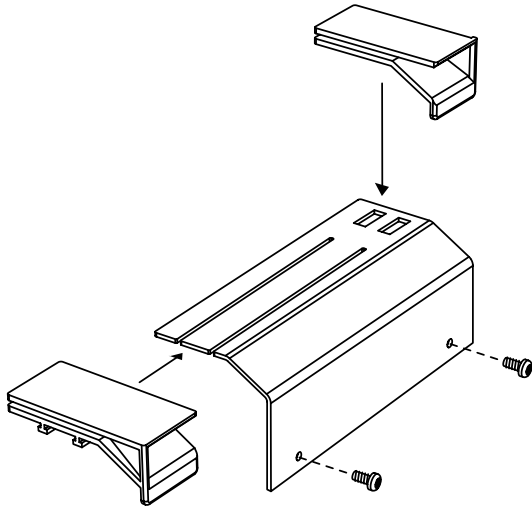

As an option, the printer can be fitted with a set of fan-fold guides in either slot.

4

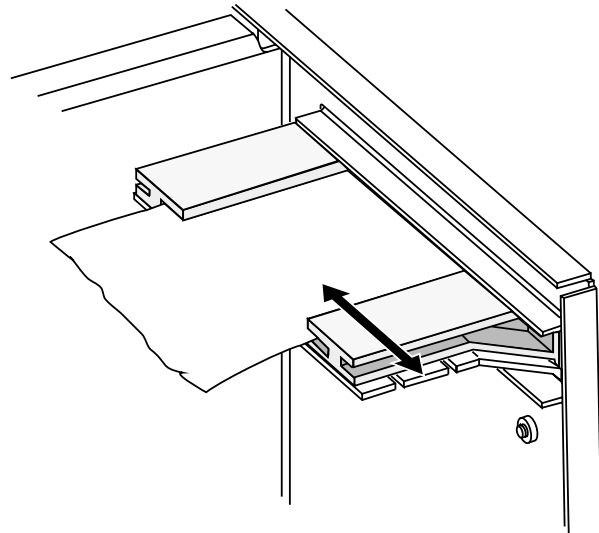

The outer guide is adjustable for different media widths (minimum 40 mm/1.575 inches).

5

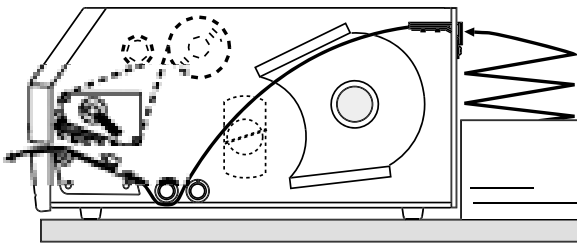

The fan-fold guide can be supplemented with an additional guide shaft and edge guide. Thread the media between the shafts.

6

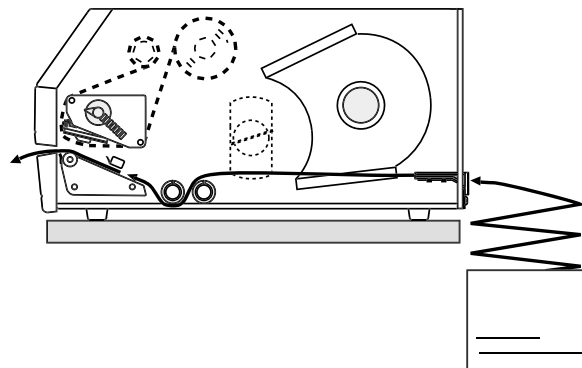

Here is the same arrangement but with the fan fold guide fitted at the lower slot.

Thermal Transfer Printing

Ribbon Load

The EasyCoder 501 S can print on labels, tickets, tags, and continuous stock using either direct thermal printing on special heat-sensitive media or thermal transfer printing using a special ink-coated ribbon. For thermal transfer printing, the printer must be fitted with a transfer ribbon mechanism.

Thermal transfer printing makes it possible to use a wide range of receiving face materials. Make sure to select a type of ribbon that matches the type of receiving face material (see Appendix 2, “Media Specification”) and to set up the printer properly (see Chapter 7, “Setting Up the Printer”).

The EasyCoder 501 S can only use transfer ribbon rolls wound with the ink-coated side facing inwards.

Most transfer ribbons do not smear at room temperature.

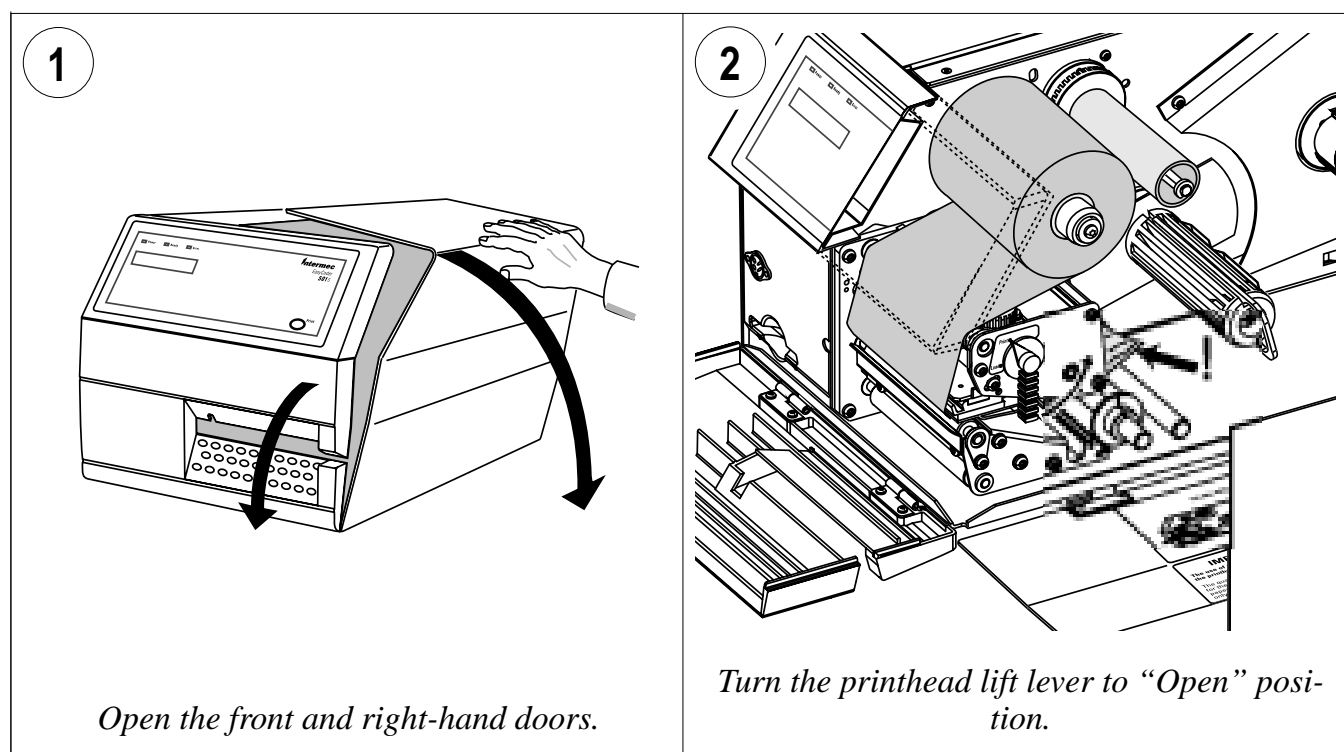

Ribbon Load, cont.

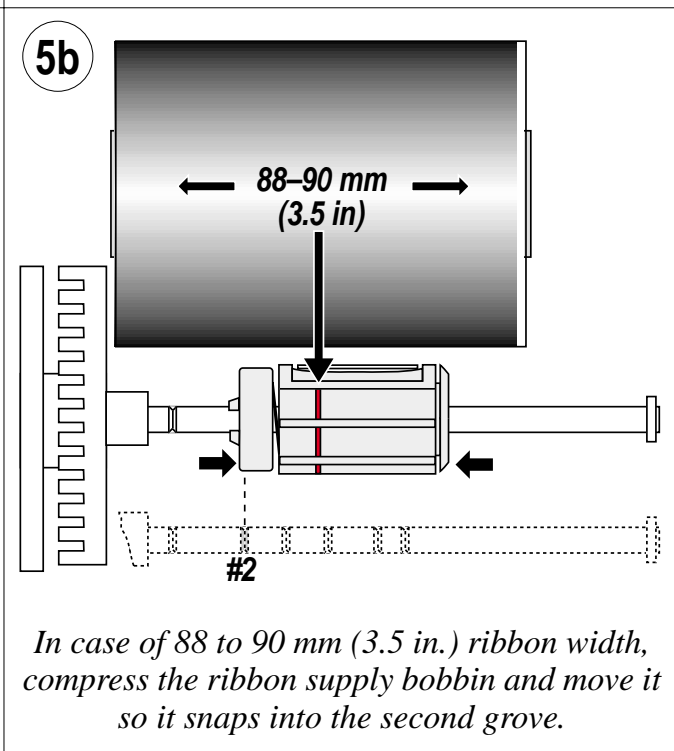
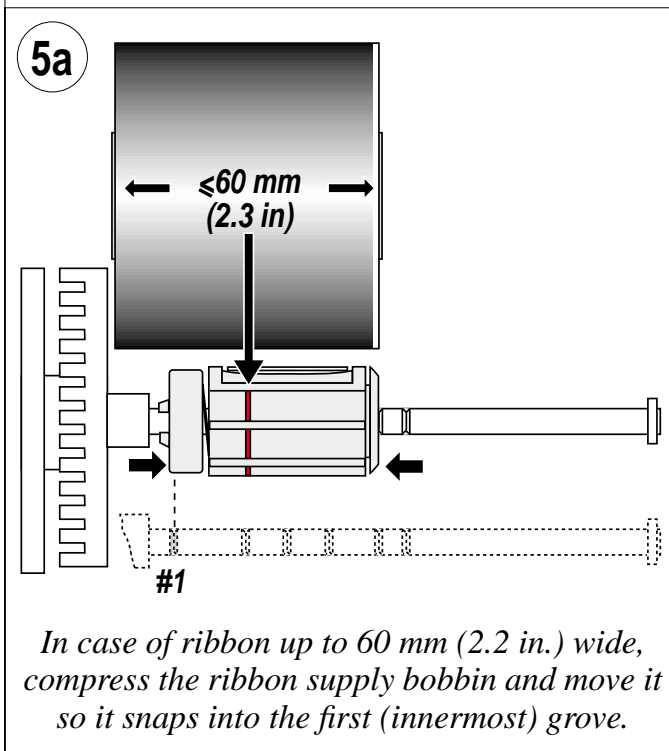
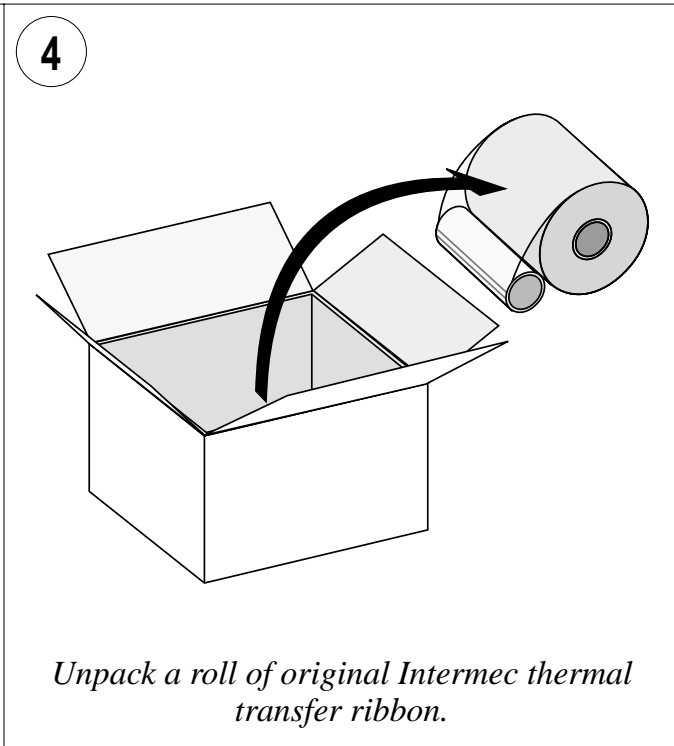
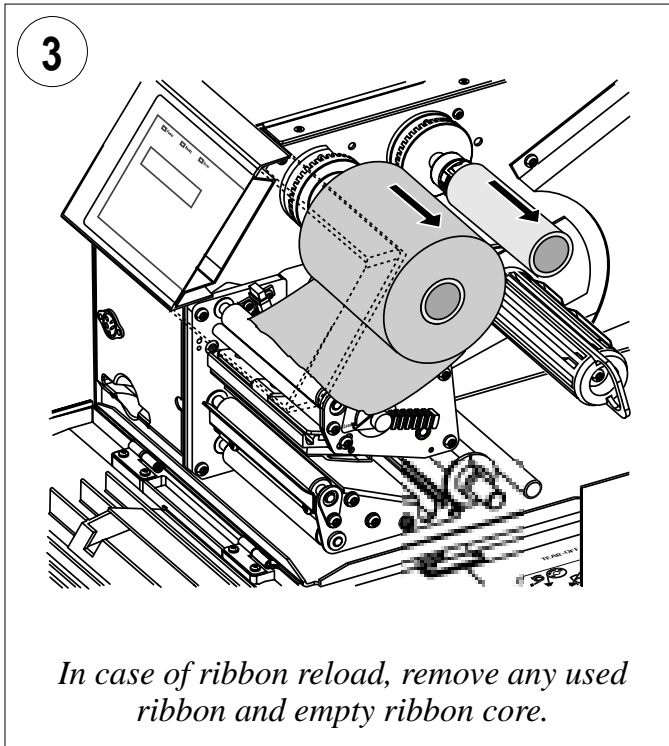

Ribbon Load, cont.

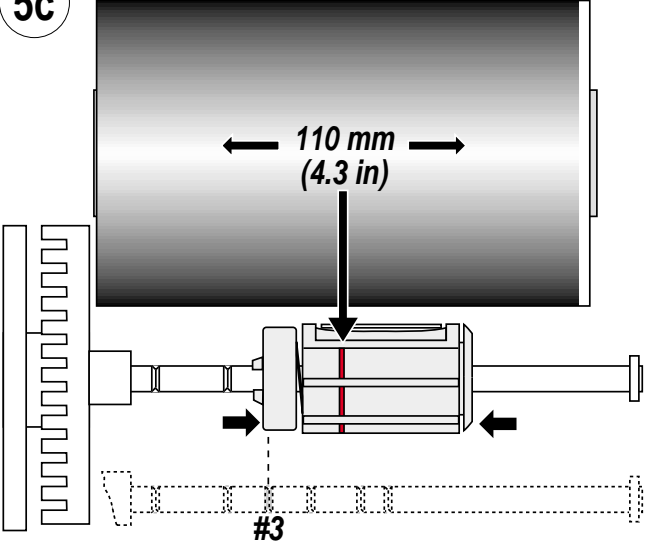
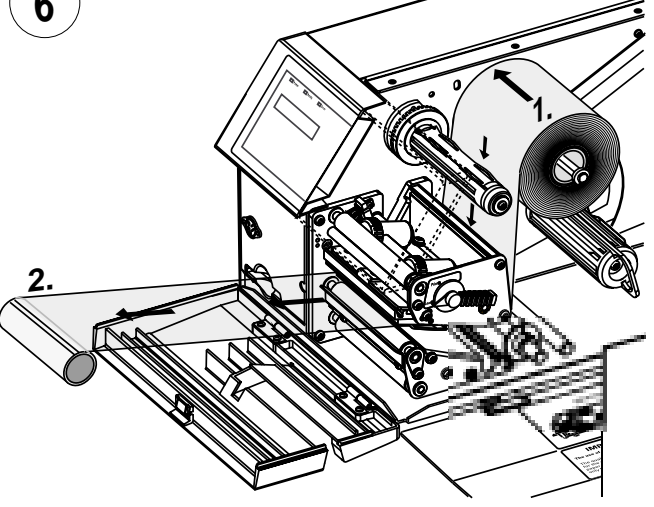
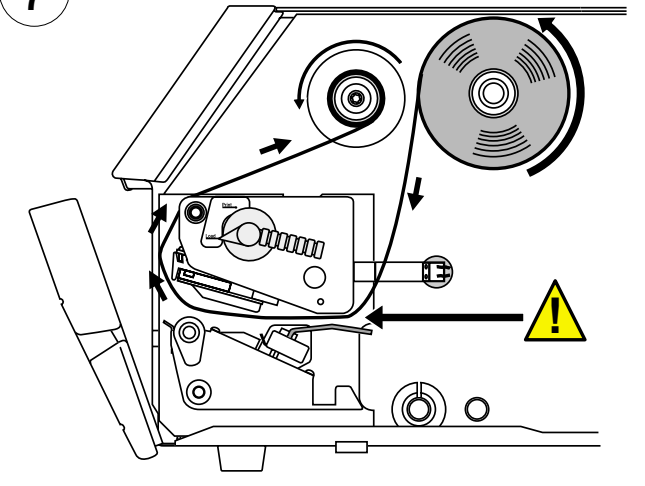
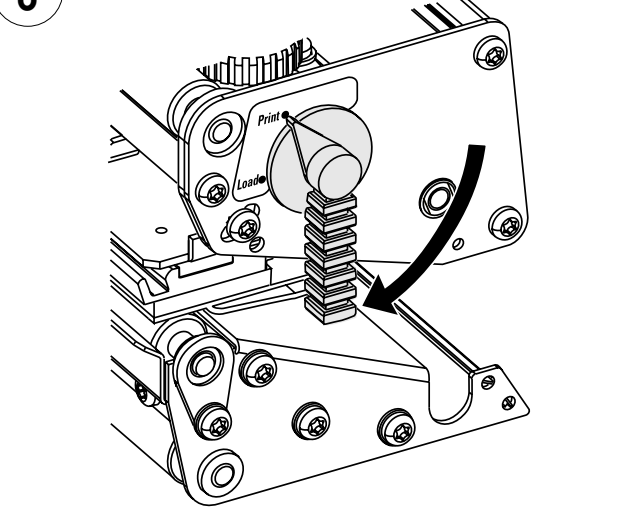
<p>5c</p>  <p><i>In case of 110 mm (4.3 in.) ribbon width, compress the ribbon supply bobbin and move it so it snaps into the third groove.</i></p>	<p>6</p>  <p><i>Press the ribbon roll onto the ribbon supply bobbin (1) and route the ribbon through the print unit. Pull out approx. 20 cm (8 in.) of ribbon (2).</i></p>
<p>7</p>  <p><i>Be careful to route the ribbon above the handle of the label stop sensor. The ribbon must be fitted so both spools will rotate counterclockwise as illustrated above.</i></p>	<p>8</p>  <p><i>Without releasing the ribbon, turn the print-head lift lever to "Print" position so as to lock the ribbon.</i></p>

Ribbon Load, cont.

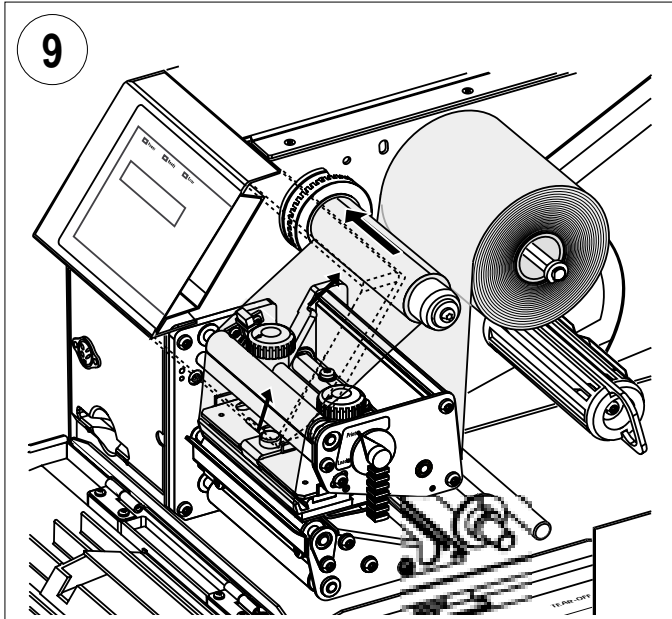

9
Press the cardboard core at the front end of the ribbon onto the rewind hub.

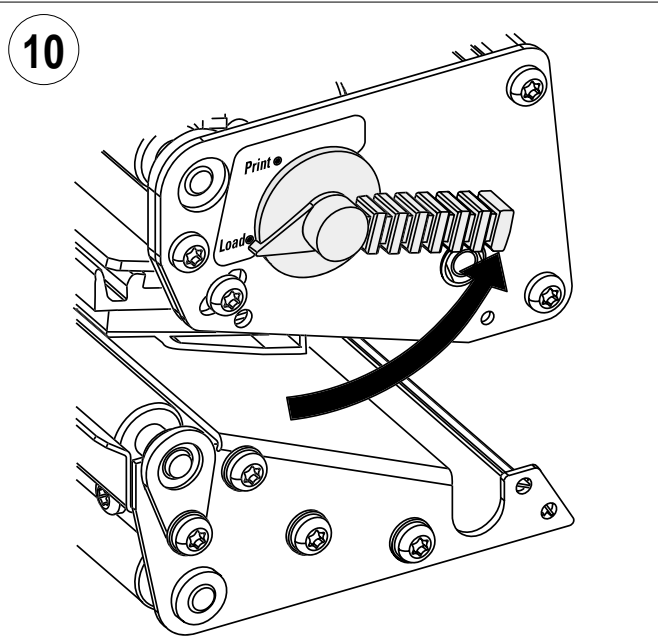

10
Turn the printhead lift lever to "Load" position.

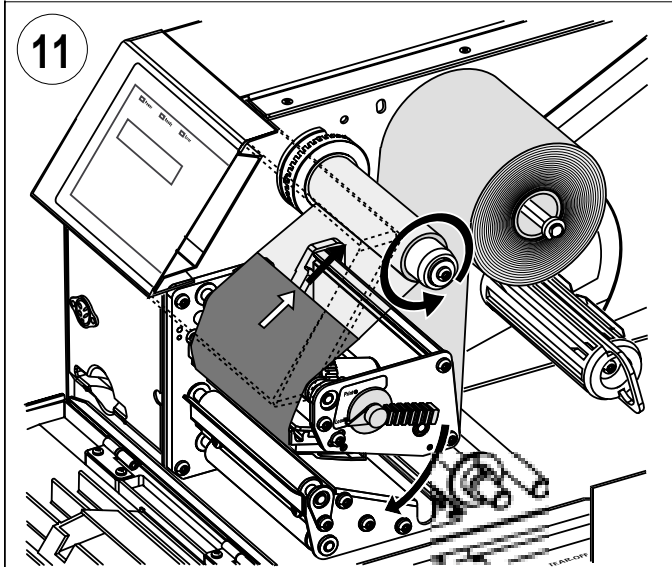

11
Wind up the ribbon until all of the transparent leader has passed the printhead and the ribbon becomes tight. Then turn the printhead lift lever to "Print position".

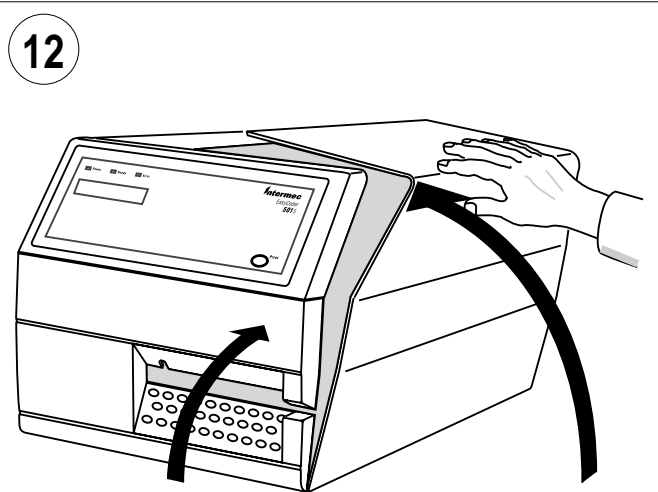

12
Close the front and side doors.

Setting Up the Printer

Description

The setup controls the printer in regard of serial communication, media feed, and print speed, and specifies which type of media and (optionally) ribbon is loaded in the printer.

Check the list of the printer's default setup parameters on the next page to see if they match your requirements. If not, you will have to change the setup using one of the methods described below. The setup may also be changed, manually or automatically, by Intermec PrintSet, InterDriver, and LabelShop, or by third-party application programs.

- **Setup Mode**
 - Select the *Setup* option in Intermec Shell to enter the Setup Mode, or
 - execute the Intermec Fingerprint *SETUP* instruction to enter the Setup Mode.
See Chapter 8, "Setup Mode".
- **Intermec Shell**
 - Use the *Terminal Setup* option to change the setup remotely from the host.
See Chapter 9, "Intermec Shell" in this manual.
- **Intermec Fingerprint**
 - Use *setup strings* to change individual setup parameters remotely from the host, or
 - use *setup files* to create sets of setup parameters remotely from the host.
See Intermec Fingerprint v6.14, Reference Manual.
- **Intermec Direct Protocol**
 - Use *setup strings* to change individual setup parameters remotely from the host.
See Intermec Direct Protocol v6.13, Programmer's Guide.

Default Setup

The printer's default setup with standard configuration EPROMs is listed below:

Contrast		Middle (5)
Ser-Com ("uart1:")	Baud rate:	9600
	Parity:	none
	Character length:	7 bits
	Stop bits:	2 bits
	RTS/CTS:	Disable
	ENQ/ACK:	Disable
	XON/XOFF, data to host:	Enable
	XON/XOFF, data from host:	Enable
	New line:	CR/LF
Detection	Feedadjust:	
	Startadjust:	0
	Stopadjust:	0
Service	Media Size:	
	X-start (8 /11.81 dots per mm):	0/0
	Width (8 /11.81 dots per mm):	832/1280
	Length (8 /11.81 dots per mm):	1200/1200
	Media type:	Label (w Gaps)
	Print defs:	
	Paper type (thermal transfer printers):	UBI HP 20
	Paper type (direct thermal printers):	RICOH 130LAB/LAM
	Performance:	Normal (fixed speed)
	Memory alloc:	
	Image buffer size:	48 Kbytes
	Receive buffer:	300 bytes
	Transmit buffer:	300 bytes

Reading the Current Setup

The printer's current setup values can be read from the printer's display window by browsing through the Setup Mode, or from the host by browsing through the Terminal Setup of Intermec Shell.

You can list the printer's current setup values by printing test label #5 in the Setup Mode or by using Intermec Shell. The current setup values can be sent to the host via the standard serial communication channel using a **SETUP WRITE "uart1:"** statement (see *Intermec Fingerprint v6.14, Reference Manual*).

Setup Parameters

Contrast

The contrast setup allows you to make minor adjustments of the printout in regard of blackness, for example to compensate for variations in quality between different batches of the same media or ribbon.

Serial Communication

- Baud Rate
- Parity
- Character Length
- Stop Bits
- Flow Control
- New Line

The serial communication parameters control the communication between the printer and the connected computer or other devices on the standard serial port "uart1:". Note that EasyCoder 501 S does not support any optional serial interface boards.

The serial communication parameters have no effect on parallel communications.

For the serial communication channel "uart1", the following parameters can be set. Make sure they match the setup of the connected device or vice versa. If the setup of the printer and the setup of the host do not match, the response from the printer to host will be garbled.

Baud Rate

The baud rate is the transmission speed in bits per second. There are seven options:

- 300
- 600
- 1200
- 2400
- 4800
- 9600 (default)
- 19200

In case of communications problems, try a lower baud rate. 9600 is the highest recommended baud rate for 20 mA current loop communication.

Setup Parameters, cont.

Serial Communication, cont.

Parity

The parity decides how the firmware will check for transmission errors. There are five options:

- None (default)
- Even
- Odd
- Mark
- Space

Character Length

The character length specifies the number of bits that will define a character. Eight bits allows more special characters and characters specific for foreign languages to be used. Refer to the *Intermec Fingerprint v6.14, Reference Manual* for information on which characters are available in various combinations of character length and character set.

- 7 Characters ASCII 000 to 127 decimal (default)
- 8 Characters ASCII 000 to 255 decimal

Stop Bits

The number of stop bits specifies how many bits will define the end of a character. There are two options:

- 1
- 2 (default)

Flow Control

There are several ways to control the exchange of data (“handshaking”) between the printer and the connected computer or other device. Each option can be enabled or disabled separately, but normally only one alternative should be enabled. For galvanically insulated interfaces (that is, 20 mA current loop and RS-422), ENQ/ACK or XON/XOFF are to prefer in order to retain interference protection and to limit the number of lines.

Setup Parameters, cont.

Serial Communication, cont.

- ***RTS/CTS***
 RTS/CTS is a protocol where the communication is controlled by currents through separate lines in the cable being set either to high or low. By default, this option is disabled.

 RTS high indicates that the transmitting unit is able to receive characters. RTS low indicates that the receive buffer is filled to 75% (see XON/XOFF).

 CTS high indicates that the unit transmitting the CTS signal is ready to receive data. CTS low indicates that the receive buffer is full (see XON/XOFF). In some computer programs, for example MS Windows Terminal, RTS/CTS is designated "Hardware."
- ***DTR***
 DTR ("Data Terminal Ready") is not controlled in the setup mode, but by straps on the CPU board or interface board. DTR high indicates that the transmitting unit is switched on.
- ***ENQ/ACK***
 In this protocol, the communication is controlled by the control characters ENQ (ASCII 05 dec.) and ACK (ASCII 06 dec.) being transmitted on the same line as the data. The sending unit transmits ENQ at regular intervals. If the response ACK is not received, the transmission is held up awaiting an ACK character from the receiving unit. By default, ENQ/ACK is disabled.
- ***XON/XOFF***
 In this protocol, the communication is controlled by the control characters XON (ASCII 17 dec.) and XOFF (ASCII 19 dec.) being transmitted on the same line as the data. XON/XOFF can be enabled/disabled separately for data received from the host by the printer (printer sends XON/XOFF) and for data transmitted to the host from the printer (host sends XON/XOFF).

 XOFF is sent from the printer when its receive buffer is filled to 75%, and the transmission from the host is held, waiting for an XON character. When enough data have been processed so the receive buffer is filled only to 50%, the printer sends an XON character and the host resumes transmitting data. The same principles apply to XON/XOFF sent by the host, even if the percentage figure may differ.

 By default, XON/XOFF is disabled for data both ways.

Setup Parameters, cont.

Serial Communication, cont.

New Line

Selects the character(s) transmitted from the printer to specify the switching to a new line. There are three options:

- CR/LF ASCII 13 dec. + ASCII 10 dec. (default)
- LF ASCII 10 dec.
- CR ASCII 13 dec.

Detection

- LSS Adjustment
- Feed Adjustment

LSS Adjustment

The LSS is a photo-electric detection device that controls the media feed. Situated inside the printing mechanism, it detects the front edges of the labels, slits in tickets or tags, or the rear edges of black marks on the back side of the media.

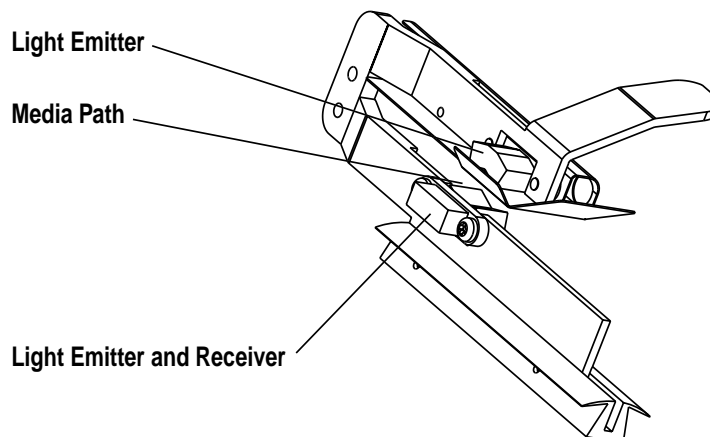

If the printer is set up for “Label (w gaps)”, “Ticket (w gaps)”, “Fix length strip”, or “Var. length strip”, a narrow beam of light is emitted from the upper part of the LSS and received by the sensor in the lower part.

Non-transparent media will block the beam completely, whereas semi-transparent liner between labels will allow some of the light to pass through.

Detection gaps in the continuous stock cause no interference at all.

An out-of-paper condition is assumed, when no interference to the beam has been detected within a feed length corresponding to the distance between the dot line on the printhead and the sensor.

Setup Parameters, cont.

Detection, cont.

LSS Adjustment, cont.

When the printer is set up for “Ticket (w mark)”, the light is emitted from the lower part of the LSS. The beam can be reflected back to the receiver by the white back side of the media. If the beam hits a black mark, practically no light will be reflected back. An out-of-paper condition is assumed, when no reflected light has been detected within a feed length corresponding to the distance between the dot line on the printhead and the sensor.

Obviously, it is important that the printer is set up for the correct type of media (see “*Media Type*” later in this chapter) so the firmware can interpret the signals correctly.

The LSS can be moved max. 50 mm sideways across the web as described in Chapter 13.

The LSS is automatically fine-adjusted when a Testfeed operation is performed. Moreover, the LSS emitters can be adjusted in regard of light intensity in the Setup part of Intermec Shell Standard (see Chapter 13) or by means of setup files, and the LSS receiver can be adjusted by means of a potentiometer on the CPU board (see Appendix 3).

If the printer works as expected, there is no need to adjust the LSS, but if the printer starts to feed out labels or tickets in an unexpected manner, check that the sensor is properly aligned in relation to the web and that it has not become dirty. Perform a few Testfeed operations to allow the sensor to auto-adjust itself.

If the error remains, proceed according to the description of the Setup Mode for the printer model in question. Only as a last resort should the potentiometer be adjusted.

Feed Adjustment

The Feed Adjustment controls how much of the media is fed out or pulled back before and/or after the actual printing. These settings are global and will be effected regardless of which program is run.

Note that the firmware detects the front edges of labels w. gaps, the ends of detection slots, and the forward edges of black marks for detection, all seen in relation to the feed direction.

Setup Parameters, cont.

Detection, cont.

Printhead Density

8 dots/mm (203.2 dpi)

Both directions:

1 dot = 0.125 mm = 4.92 mils

11.81 dots/mm (300 dpi)

Across the web (11.81 dots/mm):

1 dot = 0.085 mm = 3.33 mils

Along the web (12 dots/mm):

1 dot = 0.083 mm = 3.28 mils

Note:

The feed adjustment values listed in this chapter are approximate values to be used initially. Due to personal preferences, differences between applications, and minor mechanical differences between individual printers, the values may need to be fine-adjusted after testing.

Feed Adjustment, cont.

Start Adjust

The Start Adjust value is given as a positive or negative number of dots. Default value is 0, which places the origin a certain distance back from the forward edge of the copy.

- A **positive** start adjustment means that the specified length of media will be fed out before the printing starts. Thus, the origin is moved further back from the forward edge of the copy.
- A **negative** start adjustment means that the specified length of media will be pulled back before the printing starts. Thus, the origin is moved towards the forward edge of the copy.

Stop Adjust

The Stop Adjust value is given as a positive or negative number of dots. Default value is 0, which stops the media feed in a position suitable for tear off operation.

- A **positive** stop adjustment means that the normal media feed after the printing is completed will be increased by the specified value.
- A **negative** stop adjustment means that the normal media feed after the printing is completed will be decreased by the specified value.

Recommended Feed Adjustments (print from top of form):

Labels (peel-off)	8 dots/mm	11.81 dots/mm
Start adjust:	-90	-135
Stop adjust:	-24	-36
Tickets and Tags (tear-off)		
Start adjust:	-114	-171
Stop adjust:	0	0
Continuos stock (tear-off)		
Start adjust:	-114	-171
Stop adjust:	70	105
Cutting between labels:		
Start adjust:	-294	-441
Stop adjust:	+180	+270
Continuos stock (cut-off)		
Start adjust:	-294	-441
Stop adjust:	+250	+375

Setup Parameters, cont.

Service

- Media Size
- Media Type
- Print Defs
- Performance
- Memory Alloc

Media Size

To protect the printhead from the potentially harmful condition of printing outside the media and to allow detection of out-of-paper errors, a printable area must be specified by the use of the setup parameters *X-start*, *Width*, and *Length*.

- **X-start** specifies the position of the origin along the dots on the printhead. By default, X-start is set to 0 which corresponds to the dot closest to the printer's center section.

Printhead density	8 dots/mm	11.81 dots/mm
Number of dots on printhead:	832	1280
Max. print width:	104 mm (4.1 in)	108.3 mm (4.3 in)

By setting a value larger than 0, you will move the origin outwards, away from the inner edge of the media. In other words, the larger X-start value, the wider inner margin, and the less printable area.

- **Width** specifies the width of the printable area as a number of dots from the origin. The sum of the X-start value and the width value gives the outer margin of the printable area. The width must not be so large so as to allow printing outside the media.
- **Length** serves three purposes:
 - To decide the length of the printable area as a number of dots.
 - To decide the amount of media feed when using "fix length strip".
 - To set an "emergency stop", which works when the printer is set up for "Label (w gaps)", "Ticket (w mark)", or "Ticket (w gaps)". If the LSS has not detected a gap or mark within 150% of the set length, the media feed is automatically stopped to avoid feeding out a whole roll of media, because of a faulty sensor.

This implies that you can use labels or tickets longer than the printable area as illustrated by the following table:

Printhead density:	8 dots/mm	11.81 dots/mm
Max. print length (9999):	1,250 mm (49.2 in)	833 mm (32.8 in)
Max. copy length:	1,875 mm (73.8 in)	1,250 mm (49.2 in)

By setting up media size, you will create a "print window" in which the printing can be performed. Any field protruding outside the print window in any direction will cause an error condition (*Error 1003 "Field out of label"*) and the printing will be inhibited.

Setup Parameters, cont.

Service, cont.

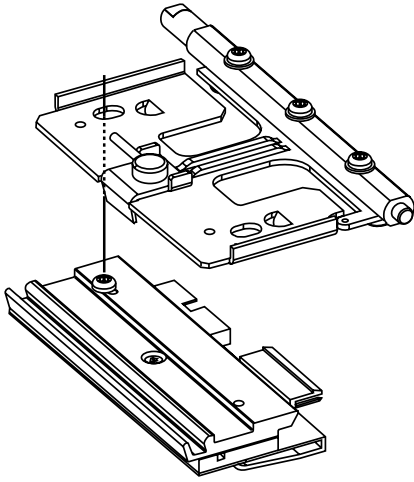

Print Window

8 dots/mm (203.2 dpi) printhead in left-hand position

The 8 dots/mm printhead can be fitted in two positions. When the printhead is fitted in the innermost, left-hand position (see illustration), dot No. 0 is aligned with the inner edge of the media. Since the maximum print width is 104 mm (4.1 in) and the maximum media width is 120 mm (4.7 in), this leaves a margin of at least 16 mm (0.6 in) along the outer edge of the media, where no printing can be performed.

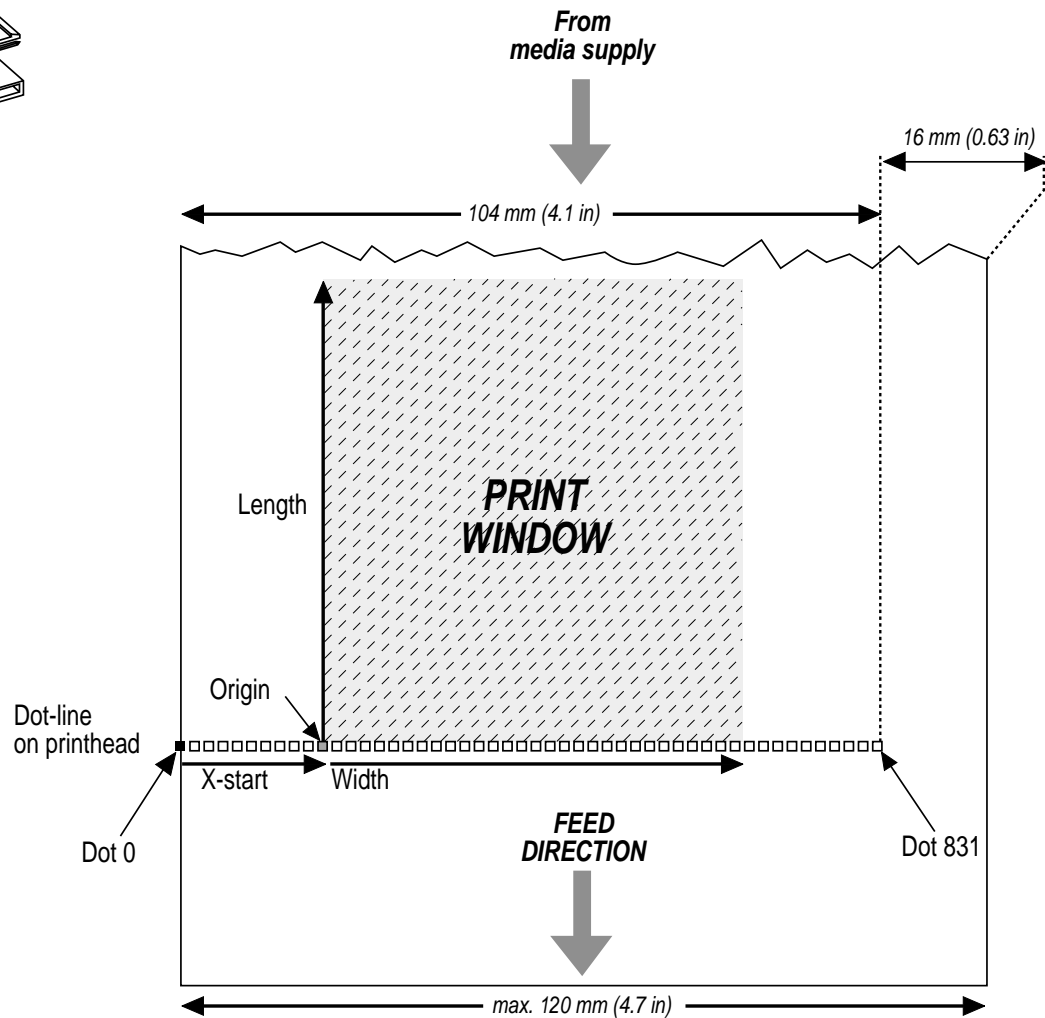

Setup Parameters, cont.

Service, cont.

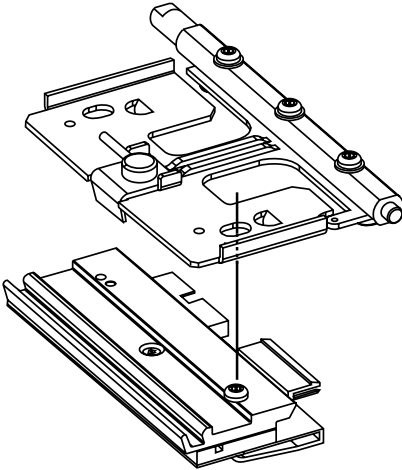

Print Window 8 dots/mm (203.2 dpi) printhead in right-hand position

The 8 dots/mm printhead can be fitted in two positions. When the printhead is fitted in the outer, right-hand position (see illustration), dot No. 0 is situated 3 mm (0.12 in) inwards from the inner edge of the media. Since the maximum print width is 104 mm (4.1 in) and the maximum media width is 120 mm (4.7 in), this leaves a margin of at least 13 mm (0.51 in) along the outer edge of the media, where no printing can be performed. Furthermore, if 110 mm (4.33 in) wide media is used, the printhead will be centered with a 3 mm (0.12 in) wide margin on either side.

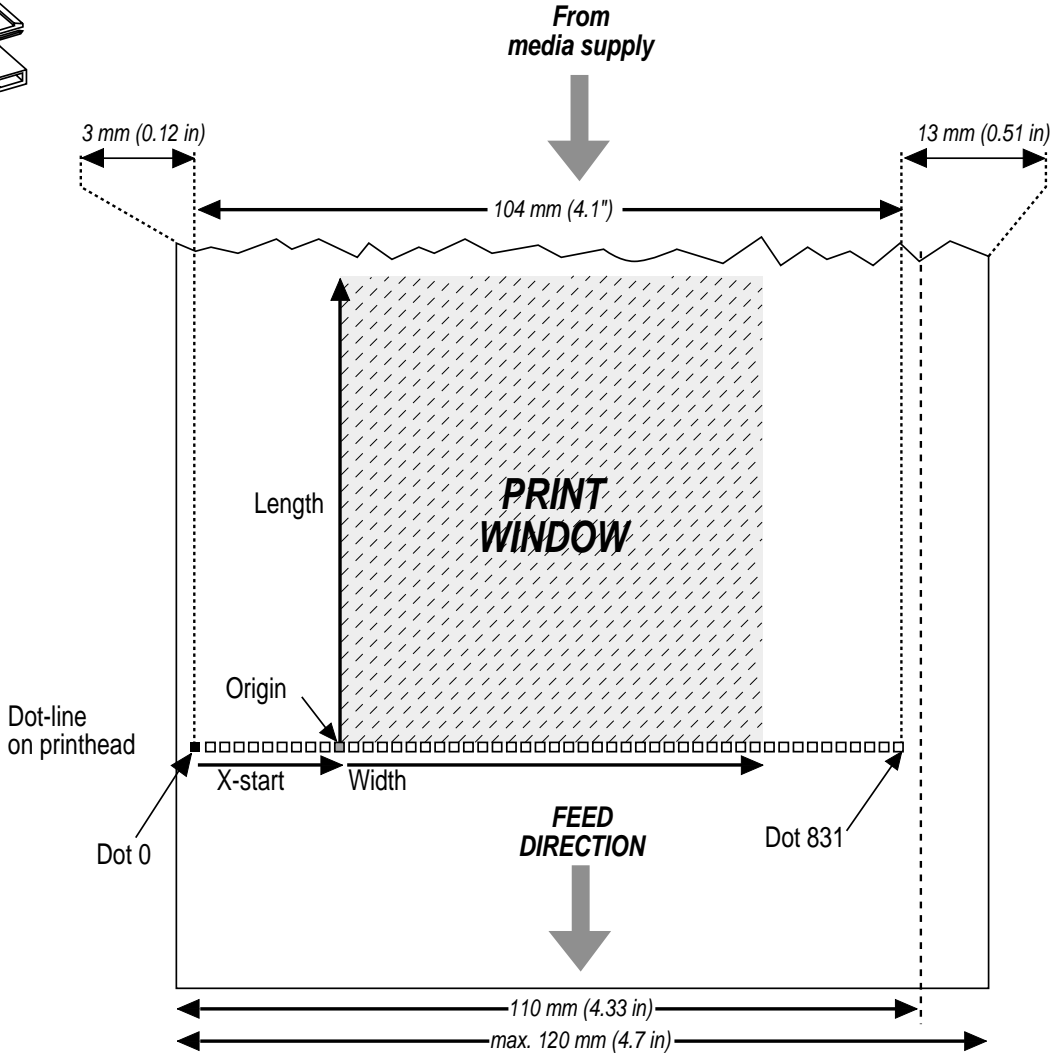

Setup Parameters, cont.

Service, cont.

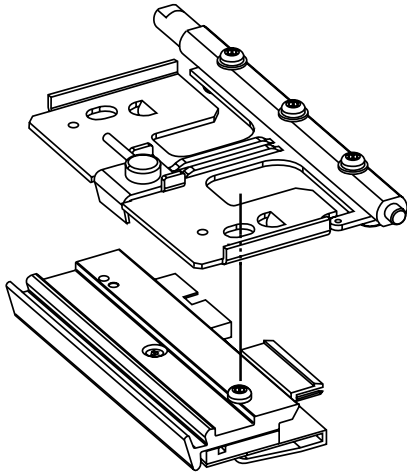

Print Window

11.81 dots/mm (300 dpi) printhead in right-hand position

The 11.81 dots/mm printhead should only be fitted in the right-hand position (see illustration). Dot No. 0 is situated 0.8 mm (0.03 in) inwards of the inner edge of the media. Since the maximum print width is 108.3 mm (4.26 in) and the maximum media width is 120 mm (4.7 in), this leaves a margin of at least 10.9 mm (0.43 in) along the outer edge of the media, where no printing can be performed.

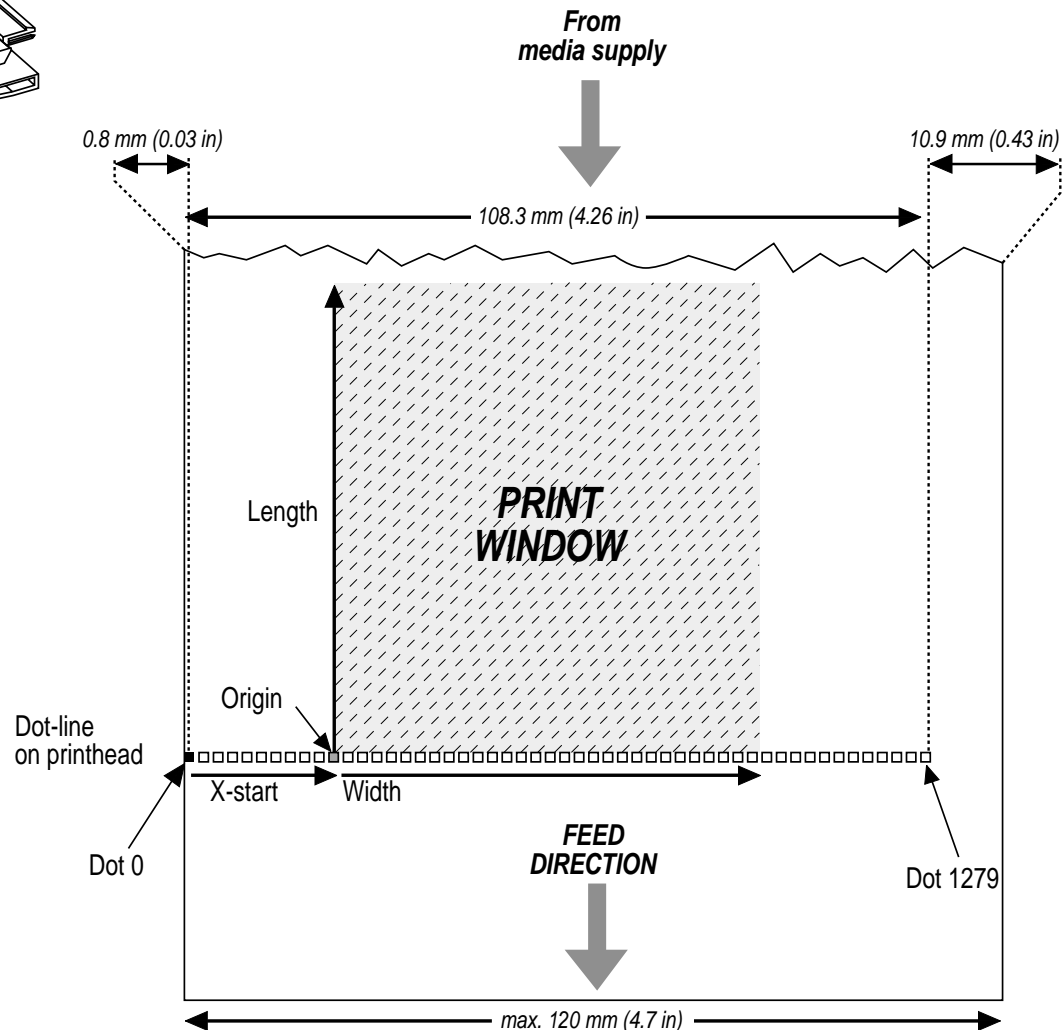

Setup Parameters, cont.

Service, cont.

Media Type

The Media Type parameters control how the label stop sensor (LSS) and the media feed work. There are five media type options:

- **Label (w gaps)** is used for adhesive labels mounted on liner.
- **Ticket (w mark)** is used for labels, tickets, or continuous stock provided with black marks at the back.
- **Ticket (w gaps)** is used for tickets and tags with detection slits.
- **Fix length strip** is used for continuous stock where the length of the print window decides the length of media to be fed out.
- **Var length strip** is used for continuous stock and adds 115 dots of media feed after the last printable dot (may even be a blank space character or a “white dot” in an image or character cell) to allow the media to be properly torn off.

It is important to select the correct media type, so the printer can indicate possible errors. Two error conditions may occur:

- *Error 1005 “Out of paper”* indicates that the last ordered copy could not be printed because of an empty media stock.
- *Error 1031 “Next label not found”* indicates that the last ordered label or ticket was successfully printed, but no more labels/tickets can be printed because of an empty media stock.

Setup Parameters, cont.

Service, cont.

Print Defs

The Print Defines section contains four types of setup parameters:

- Head Resistance
- Paper Type
- New Supplies
- Test Print

Head Resistance

The power to the printhead is adjusted automatically according to the printhead resistance each time the printer is started. There is no manual head resistance setup.

Paper Type

To obtain the best printout quality, the printer should be set up for the characteristics of the brand of direct thermal media or transfer ribbon currently used, see “Selecting Paper Type Settings” later in this chapter. Any attempt to print with transfer ribbon loaded and the printer set up for direct thermal media, or vice versa, will result in an error condition (*Error 1027 “Out of transfer ribbon” or Error 1058 “Transfer ribbon fitted”*).

Note:

In EasyCoder 501 printers without any thermal transfer mechanism, only direct thermal media options are available.

New Supplies

Other types of supplies, than those included as standard options for the Paper Type setup parameter, can be selected by means of a 13 digit code, provided by the manufacturer or distributor. Once a new supply has been selected using “New Supplies”, it will be stored in the RAM memory and appear as an additional option for the “Paper Type” parameter, where it is specified by the first 4 digits in its 13 digit code number. The first digit indicates direct thermal media (0) or thermal transfer ribbon (1).

Setup Parameters, cont.

Service, cont.

The generic term for transfer ribbons, receiving face materials, direct thermal media, and linerless media is “supplies.”

Selecting Paper Type Settings

The printer can be set for various types of supplies using of the setup parameter “Paper Type”. The “Paper Type” settings provide different levels of energy to the printhead dots to match the characteristics of the supplies in use to give the best combination of printout quality and printhead life. The use of supplies that require less energy will prolong the life of the printhead. The “Contrast” setup parameter can be used to fine-adjust the printout darkness within each “Paper Type” option.

- ***Direct Thermal Printing***

The recommended standard “Paper Type” options for direct thermal printing are shown in the table below. If you are not sure how to set the “*Paper Type*” parameter, first try the lowest energy setting (UBI DT 120), then the highest (UBI DT 110), and use the one that gives the best printout quality.

Option	Media Quality	Energy
UBI DT 120	Synthermal	Low
UBI DT 110	Premium, Economy	High

The options UBI DT 120 and UBI DT 110 are optimized for bar code printing. This may cause an impression of a somewhat weak printout for pure text and image printing. Increasing the energy to the printhead will make the printout blacker at the expense of the quality of bar codes. When extra black printout is desired for ordinary direct thermal printing, use one of the following setup options:

UBI DT 110+	15% more energy to printhead compared to UBI DT 110.
UBI DT 110++	30% more energy to printhead compared to UBI DT 110. 8 dots/mm printers only.

Due to the increased amount of energy to the printhead, they should be used with extreme care as they put high stress on the printhead. Furthermore, a more frequent cleaning of the printhead is recommended with these setup options.

The additional “Paper Type” options that can be found in the setup (“KANZAKI 86S” and “RICOH 130 LAB/LAM”) are included for compatibility reasons only and must not be understood as approval of media with the said designations.

Setup Parameters, cont.

Service, cont.

- ***Thermal Transfer Printing***

The recommended standard “Paper Type” options for thermal transfer printing are shown in the table below in order from the lowest printing energy at the top to the highest at the bottom of the table. If you are not sure how to set the “Paper Type” parameter, start with the lowest energy setting (UBI GP 11) and work your way up towards the highest (UBI HR 30), until you achieve the best printout quality. Use of higher “Paper Type” levels than listed for each ribbon type should be avoided, but lower levels are preferred whenever an acceptable printout quality is obtained.

Option	Ribbon Type	Face Material	Energy
UBI GP 11	General Purpose/	Matte Coated	Low
UBI GP 10	Standard	Vellum/Uncoated	↓
UBI HP 21	High Performance/	High Gloss White	↓
UBI HP 20¹	Premium	Matte Coated	↓
UBI HR 31	High Resistance/	Polyester Gloss	↓
UBI HR 30	Super Premium	Polyester Matte	High

¹/. Also try UBI HP 21.

Setup Parameters, cont.

Service, cont.

Testprint

This option allows you to print a series of test labels as illustrated below. The labels are the same as in the “Test Label” option in the Intermecc Shell program, see Chapter 9.

First, four test labels intended to facilitate adjustment of the printhead pressure and alignment are printed. Then comes one or more labels showing the printer's current setup, before the loop starts all over again.

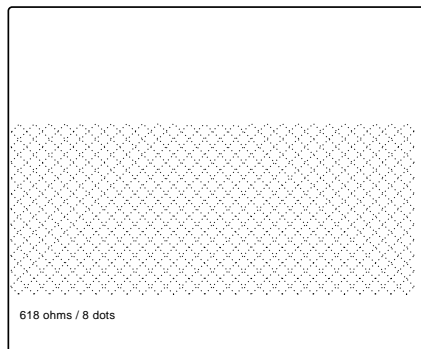

Test Label 1

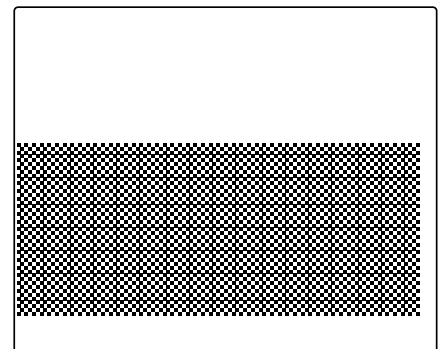

Test Label 2



Test Label 3

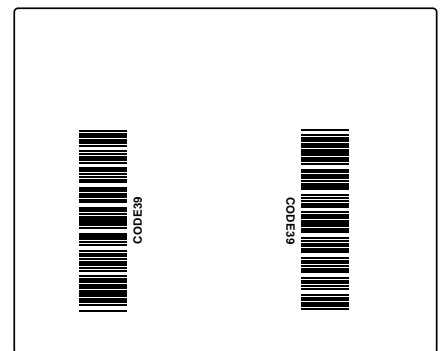

Test Label 4

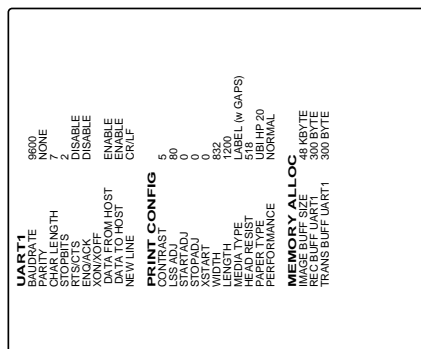

Test Label 5...

Setup Parameters, cont.

Service, cont.

Performance

The Performance setup parameter has no meaning for the EasyCoder 501 S, because it has fixed print speed of 100 mm/sec. (4 inches/sec.) regardless of supplies and printhead density.

Memory Allocation

The Memory Allocation parameters allow you to set the size for three kinds of memory buffers:

- The **Image Buffer** stores the printout image before printing and during batch printing. To ensure that high print speed is sustained during the printing of demanding label formats, the size of the Image Buffer may need to be increased. The maximum size of the image buffer is 250 kbytes.
- The **Receive Buffer** stores the input data received on the serial communication channel "uart1:" before processing..
- The **Transmit Buffer** stores the output data on the serial communication channel "uart1:" before transmission.

Setup Mode

Setting Up EasyCoder 501 S

The EasyCoder 501 S (Standard) is intended for applications, where the printing will be controlled from a host computer and very little action is required by the operator. Accordingly, there is only one key available on the membrane keyboard on this type of printer.

The use of optional serial interface boards have been excluded from this model. The same applies to the choice of performance level.

The method of changing the setup depends on whether the printer is fitted with some kind of startup file, a subject that was more thoroughly discussed in Chapter 4.

EasyCoder 501 S with Intermec Shell

- You can change any setup parameter via the Terminal Setup option in Intermec Shell Standard, see Chapter 9.
- You can change the LSS setup via the Setup option of Intermec Shell, see Chapter 13.
- As an alternative, you can also change the setup using a setup file or setup string, see SETUP statement in the *Intermec Fingerprint v6.14, Reference Manual* or in the *Intermec Direct Protocol v6.13, Programmer's Guide*.

EasyCoder 501 S with no startup file installed

- An EasyCoder 501 S without any startup file can only be set up by means of setup files or setup strings, see SETUP statement in the *Intermec Fingerprint v6.14, Reference Manual* or in the *Intermec Direct Protocol v6.13, Programmer's Guide*.

EasyCoder 501 S with a custom-made application program

- Normally, necessary provisions for changing the setup should be provided by the program by means of setup files or setup strings, see SETUP statement in the *Intermec Fingerprint v6.14, Reference Manual* or in the *Intermec Direct Protocol v6.13, Programmer's Guide*.

Intermec Shell Startup Program

Introduction

Intermec Shell is a startup program (also called “autoexec-file”), which is a program that automatically starts running when the printer is switched on. Intermec Shell helps the operator to choose between a number of standard or custom-made application programs and to start certain useful facilities, as listed below.

Application Programs

- Intermec LabelShop *(WYSIWYG label design program)*
- Intermec Windows Driver *(do not use)*
- Intermec Fingerprint *(for creating your own programs or to run the Intermec InterDriver)*
- Intermec Direct Protocol *(easy-to-use slave protocol)*
- LINE_AXP.PRG *(line analyzer program)*
- Other application programs in the printer’s memory.

A prerequisite is that the program is provided with the extension “.PRG”. However, some original Intermec utility programs are excluded as long as they remain stored in "rom:":

- ERRHAND.PRG
- ERRHAND910.PRG
- FILELIST.PRG
- MKAUTO.PRG
- TEST910.PRG

Other Facilities

- Terminal Setup *(remote setup ans Shell control)*
- Setup Mode *(manual setup from printer’s keyboard)*
- Print Setup *(printing setup on label)*
- Testfeed *(formfeeds + auto-adjust of the LSS)*
- Test Label *(printing of test labels)*
- Ser-Com Reset *(resetting all setup parameters to default)*
- Clear RAM *(erasing the printer’s RAM memory)*
- Reboot *(restarting the printer)*

Introduction, cont.

There can be one startup file stored in each of the following parts of the printer's memory: RAM, ROM, and a memory card inserted in the printer's optional memory card adapter. If there are startup files stored in more than one place, they will be used with the following priority:

1. DOS-formatted memory cards (SRAM).
2. Printer's RAM memory.
3. Non DOS-formatted memory cards (SRAM or OTPROM).
4. Printer's ROM memory, for example the configuration EPROMs.

This implies that if you, for example, have Intermec Shell stored in the printer's configuration EPROMs and insert a memory card with another startup file before you switch on the printer, the startup file of the memory card will be used.

<i>EPROM</i>	=	<i>Erasable Programmable Read-Only Memory</i>
<i>OTPROM</i>	=	<i>One-Time Programmable Read-Only Memory</i>
<i>RAM</i>	=	<i>Random Access Memory</i>
<i>ROM</i>	=	<i>Read-Only Memory</i>
<i>SRAM</i>	=	<i>Static Random Access Memory</i>

Because the EasyCoder 501 S only has one key on its front panel, you must combine it with the printhead lift lever to navigate in Intermec Shell and to select various options.

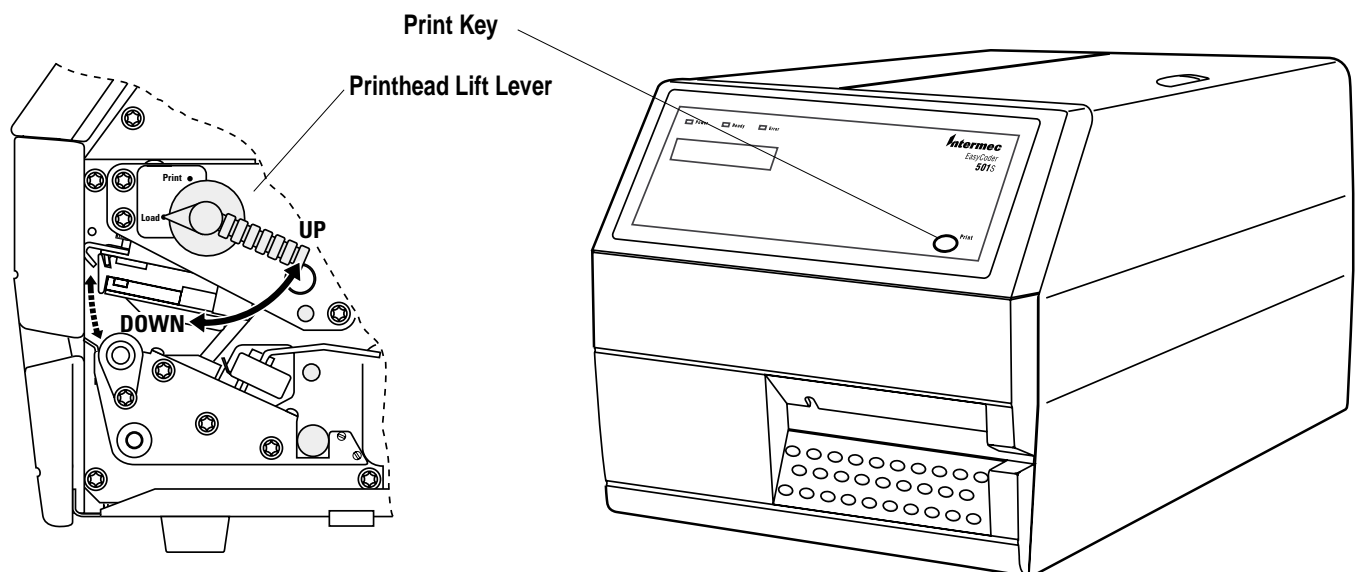

Starting with Intermec Shell

A few seconds after you have switched on the power to the printer and the initialization is completed, the countdown menu of the Intermec Shell program will be displayed:

```
PRINT=SHELL
5 sec.    v.4.01
```

Now you have 5 seconds to enter Intermec Shell by pressing the **<Print>** key with the printhead lowered. (The printhead should always be lowered at startup.)

Provided you have a working two-way communication with a terminal program in a host computer, you may, as an alternative, enter the Terminal Setup by transmitting “**TTT**” or “**ttt**” to the printer. The Terminal Setup is described later in this chapter.

The lower line tells you how much time you have left. Should the time run out before you have taken any action to enter Intermec Shell, the last selected application in Intermec Shell will be opened. If you use the same application all the time, you will only need to switch on the power, once the application has been selected.

If no other application has yet been selected, the current version of Intermec Fingerprint will be opened with the standard RS-232 port “uart1:” selected as std I/O channel (see Intermec Fingerprint manuals). When the countdown is completed, you will see these lines in the display:

```
FINGERPRINT
6.14
```

If you want to select another application, just cycle the power and enter Intermec Shell before the countdown is completed.

When you enter the Intermec Shell from the countdown menus, the Select Application menu will be displayed:

```
SHELL
SEL. APPLICATION
```

In this menu, you can choose between three options:

- Press **<Print>** without lifting the printhead to go to menus where you can select an application program.
- Lift the printhead and press **<Print>** to go to the Facilities part of Intermec Shell.
- Start the Terminal Setup program by transmitting “**TTT**” or “**ttt**” from the host.

Starting with Intermec Shell, cont.

When an application program is started, it may automatically change the communication setup. For example, Intermec LabelShop changes the setup to the following values:

<i>Baud rate:</i>	<i>57600</i>
<i>Parity:</i>	<i>None</i>
<i>Char. length:</i>	<i>8</i>
<i>Stopbits:</i>	<i>1</i>
<i>RTS/CTS:</i>	<i>Enable</i>
<i>ENQ/ACK:</i>	<i>Disable</i>
<i>XON/XOFF to host:</i>	<i>Disable</i>
<i>XON/XOFF from host:</i>	<i>Disable</i>
<i>New line:</i>	<i>CRLF</i>
<i>Receive buffer:</i>	<i>600</i>
<i>Transmit buffer:</i>	<i>600</i>

If another application is selected later, this communication setup will remain valid, unless the new application includes instructions that automatically change the setup. The setup could also be changed using setup strings or files or using the Terminal Setup.

In Intermec Shell, the menus present the option in infinite loops, To see all the menus and options, refer to the overview later in this chapter.

Select Application

The Select application lets you choose an application program that resides in the printer's memory.

Note that after having selected an application, you must wait for the printer to restart and perform the 5 seconds countdown before the selected application is opened.

- **Current appl.** starts the last selected application (by default Intermec Fingerprint with "uart1:" selected as standard I/O channel).
- **LabelShop** selects the standard serial interface "uart1:" as standard IN/OUT channel and sets up the printer for the various versions of the Intermec LabelShop label design program for MS Windows. Refer to the Intermec LabelShop manuals.
- **Windows Driver** selects the optional parallel interface "centronics:" as standard IN/OUT channel..
- **Fingerprint** is used to create, modify, or run programs written in the Intermec Fingerprint programming language and to run the Intermec InterDriver. This option requires that you also select a standard IN/OUT channel, which is the channel you want to use for communication between the printer and the computer. Normally, you select "uart1:". Refer to the Intermec Fingerprint manuals.
- **Direct Protocol** is an easy-to-use printer protocol for downloading label formats and variable input data to a printer from a host computer. This option requires that you also select a standard IN/OUT channel, that is, the serial channel you want to use for communication between the printer and the host. Normally, you select "uart1:". Refer to the *Intermec Direct Protocol v6.13, Programmer's Guide*.
- **LINE-ALY.PRG** (Line Analyzer) is a Fingerprint program that captures characters received by the printer on a specified communication channel and prints them on labels. (See later in this chapter.)
- **Other Application Programs**
If the printer contains any other application programs, standard or custom-made, these will presented as additional options.

Starting with Intermec Shell, cont.

Select Other Facilities

As an alternative to selecting an application, you can step through a number of other useful facilities:

- **Setup** allows you to enter the Setup Mode where you can set up the printer in regard of LSS adjustment, see Chapter 13 “Adjustments/Label Stop Sensor.” You can also read the current setup as described later in this chapter.
- **Print Setup** allows you to produce a printout of the printer’s current setup values (test label #5...).
- **Testfeed** allows you to feed out one label, ticket, tag, or portion of continuous stock while the printer auto-adjusts its media feed and label stop/black mark sensor. It is recommended to perform at least two Testfeeds.
- **Test Label** allows you to print a series of four test labels (test labels #1 to #4) in order to test the printout quality and printhead alignment. The labels are presented in an infinite loop, so you can print the series over and over again. Press <Enter> for each new label.
- **Ser-Com Reset** allows you to reset the serial communication setup parameters for the serial communication channel "uart1:" to its default value (see Chapter 7).
- **Clear RAM Memory** is used to erase most of the printer’s RAM memory in order to provide more memory space, if necessary. Only use the Clear Memory option when you experience problems with printing using a printer driver and when you are sure that you do not have any irreplaceable files in the RAM memory!

The Clear RAM Memory option is protected by a password (491601) to avoid being activated unintentionally.

- **Reboot** has the same effect as switching off and on the power to the printer. To exit Intermec Shell without having selected any application program, use Reboot or restart the printer. Then wait for the 5 seconds countdown without taking any action, and the last selected application will be opened.

Intermec Shell v4.01 Standard, Main Diagram

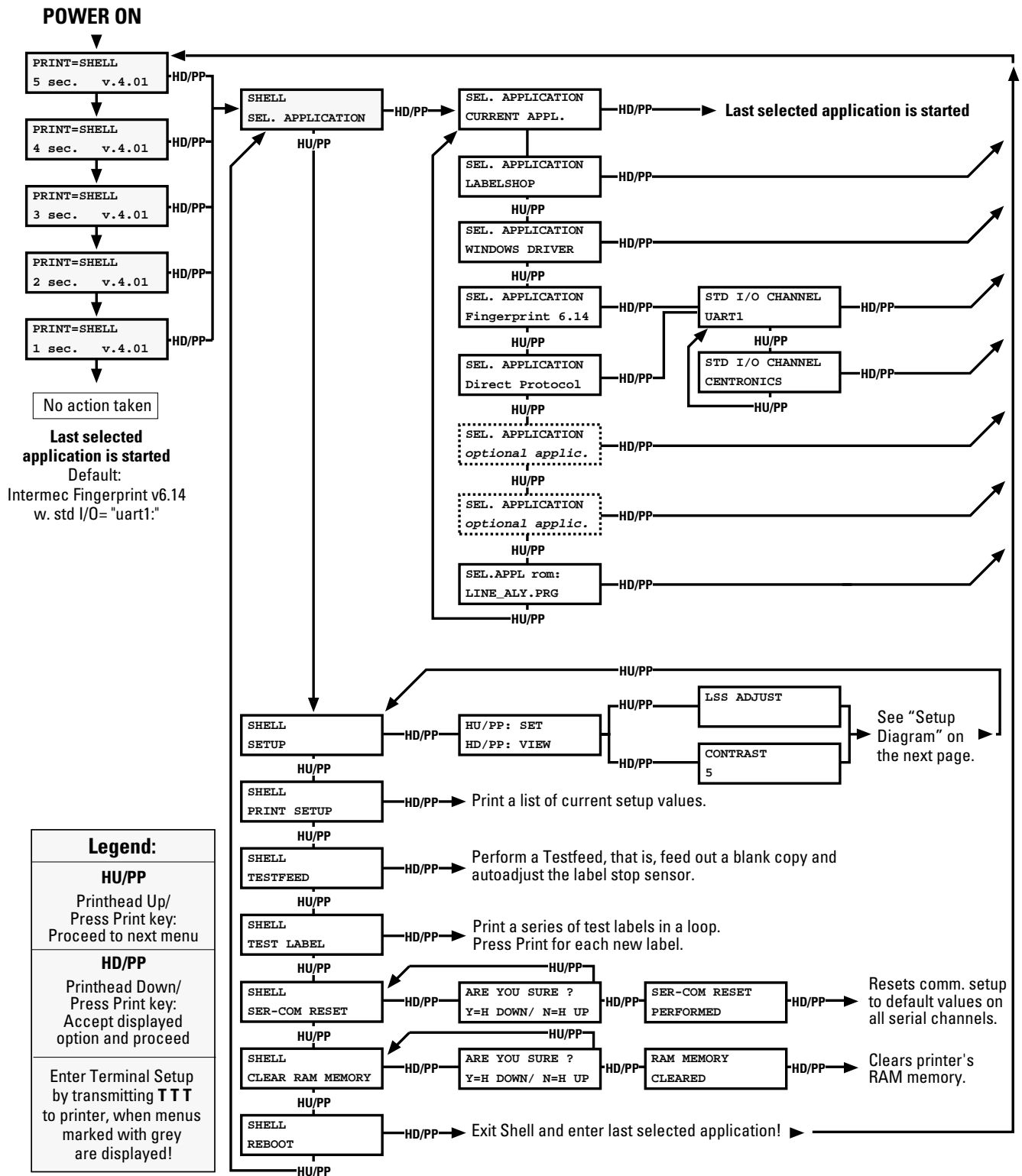

Intermec Shell v4.01 Standard, Setup Diagram

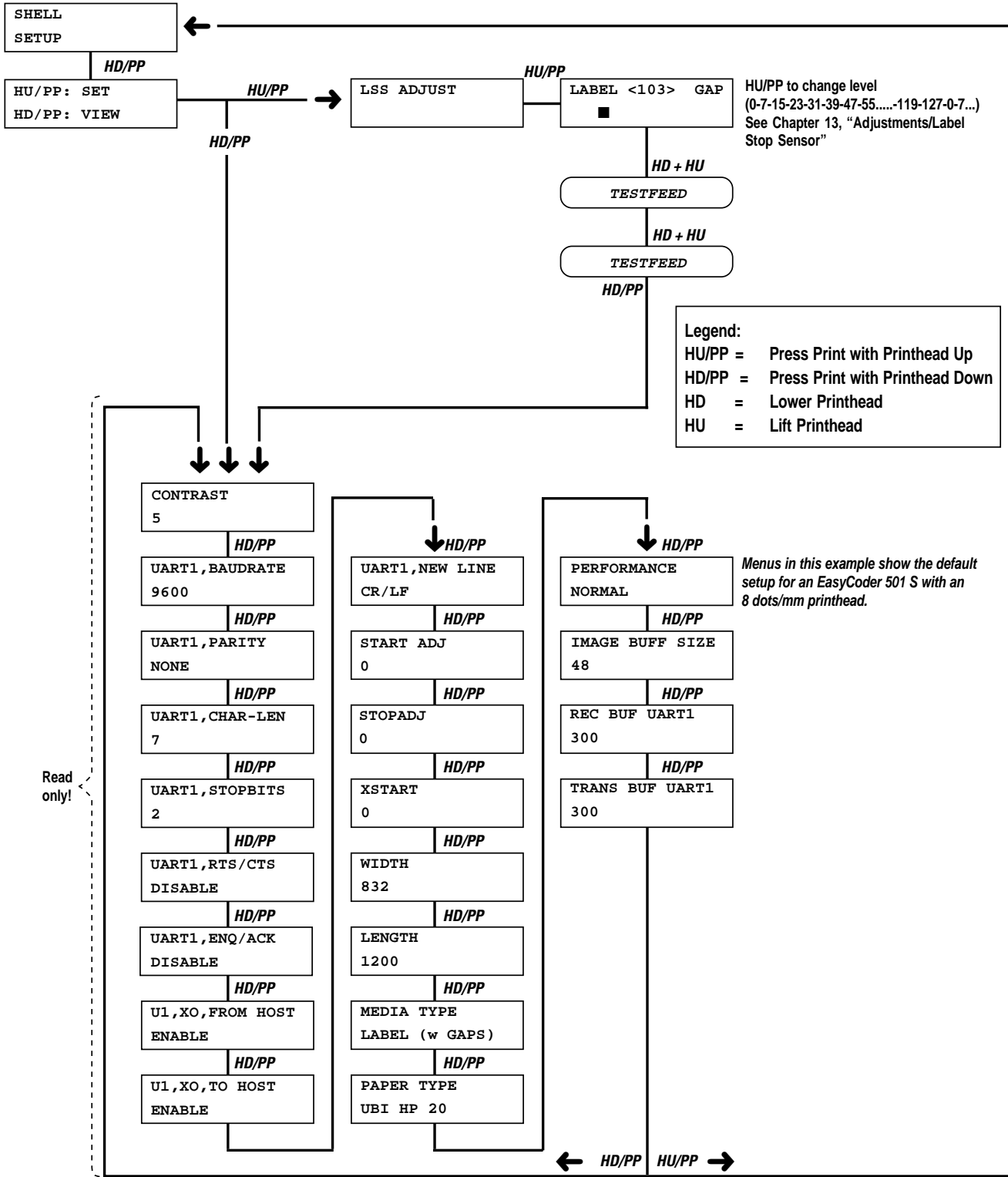

Terminal Setup

Starting Terminal Setup

The Terminal Setup program in Intermec Shell allows the operator to control the whole Intermec Shell program remotely from a host computer or terminal and to read or change the printer's setup. There must be a working two-way (serial) communication between printer and host, and the host must be running a suitable communication program (for example MS Windows HyperTerminal) that can transmit and receive data in ASCII format; that is, as printable characters. Set up the terminal as VT100.

Enter Terminal Setup by transmitting three upper- or lowercase **T** characters (**TTT** or **ttt**) while the printer either shows the Intermec Shell countdown menus or the Select Application menu.

Solving Communication Problems

If you cannot start Terminal Setup, the communication protocols of the printer and the host probably do not match, or there is some other communication error. For example, you may have a defective communication cable, the wrong port may be selected on the host, or the cable is not connected to "uart1:" on the printer.

You can check the printer's setup in Intermec Shell. Among the facilities in Intermec Shell, you will find a number of options that allow you to read or change the communication setup of the printer:

- **Setup**
This option allows you to read the communication setup.
- **Print Setup**
Here you can print the current setup on one or more labels.
- **Ser-Com Reset**
This option allows you to reset the communication parameters for the serial communication channel "uart1:" to its default values.

Change the communication setup of the host according to the printer's setup. If that is not possible, reset the printer's communication setup to default using the Ser-Com Reset option and change the setup of the host accordingly.

Once printer and host have been set up with the same communication parameters, go to the "Select Application" menu and use the triple T (**TTT** or **ttt**) to start Terminal Setup.

Terminal Setup, cont.

Using Terminal Setup

The Terminal Setup program uses prompts to help you navigate.

Comprehensive explanations of the various setup parameters can be found in Chapter 7, “Setting Up the Printer.”

When you transmit the triple T (**TTT** or **ttt**) to the printer, the following message will appear on the printer’s display:

```
SETUP FROM
TERMINAL
```

On the screen of the host, another message will appear:

```
-----
Welcome to SHELL v.4.01 in terminal mode
-----
```

Answer Y <CR> for Yes, <CR> for No.

```
-----
SHELL
SEL. APPLICATION
-----
```

(Y/N/B):

From here on, you can move around in Intermec Shell according to the diagram in the chapter “Using Intermec Shell” by answering **Y** (Yes), **N** (No), or **B** (Back) to the prompts that appear on the screen.

Note that the program also accepts lowercase characters (y, n, and b).

Terminal Setup, cont.

Selecting an Application

This example shows how you can select the Intermec Fingerprint application:

```
-----
SHELL
SEL. APPLICATION
-----
```

```
(Y / N / B):Y
-----
```

```
SEL. APPLICATION
CURRENT APPL.
-----
```

```
(Y / N / B):N
-----
```

```
SEL. APPLICATION
LABELSHOP
-----
```

```
(Y / N / B):N
-----
```

```
SEL. APPLICATION
WINDOWS DRIVER
-----
```

```
(Y / N / B):N
-----
```

```
SEL. APPLICATION
Fingerprint 6.14
-----
```

```
(Y / N / B):Y
-----
```

```
STD I/O CHANNEL
UART1
-----
```

```
(Y / N / B):Y
```

When you have answered the final prompt, the printer will exit Terminal Setup, reboot, and start the selected application.

Terminal Setup, cont.

Changing the Setup

If you want to set up the printer or use any other of the facilities, you should answer N (=No) to the “Select Application” prompt. The following example illustrates how to change the printer’s communication setup from 19,200 baud to 9,600 baud:

```
-----  
SHELL  
SEL. APPLICATION  
-----
```

(Y / N):N

```
-----  
SHELL  
SETUP  
-----
```

(Y / N):Y

```
-----  
SETUP FROM  
TERMINAL  
-----
```

Reading printer setup, please wait.
If no change, press ENTER
To end terminal setup: enter QUIT (Q), or QUIT and SAVE (S)

CONTRAST,5
New value: (0-10) :

UART1,BAUDRATE,19200
New value: (1:300 2:600 3:1200 4:2400 5:4800 6:9600 7:19200) :6
Comment: You must specify the baudrate by a digit (1–7) according to the displayed list of options and then press enter.

UART1,PARITY,NONE
New value: (1:NONE 2:EVEN 3:ODD 4:MARK 5:SPACE) :S
Comment: Enter Q to quit without saving, or S to save the new setup and quit the Terminal Setup.

Are you sure? (Y / N):Y

```
xf~xxff xx~f ffffffffxxxxf ff ffffffffxxxx~fx  
Comment: Since you have changed the communication parameters, the messages from the printer will become garbled. Change the terminal’s setup so it matches the printer’s.
```

Terminal Setup, cont.

Exiting Terminal Setup

To exit the Terminal Setup program, step through all the facility options and select Reboot, as illustrated below:

```

-----
SHELL
PRINT SETUP
-----

(Y / N / B):N
-----
SHELL
TESTFEED
-----

(Y / N / B):N
-----
SHELL
TEST LABEL
-----

(Y / N / B):N
-----
SHELL
SER-COM RESET
-----

(Y / N / B):N
-----
SHELL
CLEAR RAM MEMORY
-----

(Y / N / B):N
-----
SHELL
REBOOT
-----

(Y / N / B):Y

```

If you answer N (=No) at the Shell Reboot prompt, you will return to the “Select Application” option, but if you answer Y (=Yes) the printer will start up again and begin the Intermec Shell countdown. Then you can enter Terminal Setup once more by transmitting a triple T, enter the Intermec Shell manually by pressing <Print> with the printhead lowered in the countdown menus, or return to the last selected application by waiting for the countdown to be completed without taking any action.

Terminal Setup, cont.

Setup Parameters

The displayed values refer to the default setup of an 8 dots/mm EasyCoder 501 S.

SETUP FROM
TERMINAL

Reading printer setup, please wait.

If no change, press ENTER

To end terminal setup: enter QUIT (Q), or QUIT and SAVE (S)

CONTRAST,5

New value: (0-10) :

UART1,BAUDRATE,9600

New value: (1:300 2:600 3:1200 4:2400 5:4800 6:9600 7:19200) :

UART1,PARITY,NONE

New value: (1:NONE 2:EVEN 3:ODD 4:MARK 5:SPACE) :

UART1,CHAR LENGTH,7

New value: (1:7 2:8) :

UART1,STOPBITS,2

New value: (1:1 2:2) :

UART1,FLOWCONTROL,RTS/CTS,DISABLE

New value: (1:ENABLE 2:DISABLE) :

UART1,FLOWCONTROL,ENQ/ACK,DISABLE

New value: (1:ENABLE 2:DISABLE) :

UART1,FLOWCONTROL,XON/XOFF,DATA FROM HOST,ENABLE

New value: (1:ENABLE 2:DISABLE) :

UART1,FLOWCONTROL,XON/XOFF,DATA TO HOST,ENABLE

New value: (1:ENABLE 2:DISABLE) :

UART1,NEW LINE,CR/LF

New value: (1:CR/LF 2:LF 3:CR) :

DETECTION,LSS ADJUST,80

New value: (0-127) Press F <CR> for testfeed. Press <CR> when OK :

DETECTION,FEEDADJ,STARTADJ,0

New value: (-9999 thru +9999) :

DETECTION,FEEDADJ,STOPADJ,0

New value: (-9999 thru +9999) :

MEDIA SIZE,XSTART,0

New value: (0-999) :

MEDIA SIZE,WIDTH,832

New value: (0-9999) :

MEDIA SIZE,LENGTH,1200

New value: (0-9999) :

MEDIA TYPE,LABEL (w GAPS)

New value: (1:LABEL (w GAPS) 2:TICKET (w MARK) 3:TICKET (w GAPS))

(4:FIX LENGTH STRIP 5:VAR LENGTH STRIP) :

Note:

After you have pressed CR, a series of additional prompts will appear where you can adjust the LSS following the same principles as described in Chapter 13 "Adjustments".

Terminal Setup, cont.

Setup Parameters, cont.

PRINT DEFS,HEAD RESIST,519

New value: measured

PRINT DEFS,PAPER TYPE,UBI HP 20

New value:

0:RICOH 130LAB/LAM	1:KANZAKI 86S	2:UBI DT 110++	3:UBI DT 110+
4:UBI DT 110	5:UBI DT 120	6:UBI GP 10	7:UBI GP 11
8:UBI HP 20	9:UBI HP 21	10:UBI HR 31	11:UBI HR 30

Select paper type, (0-11):

PRINT DEFS,NEW SUPPLIES

New value:

PERFORMANCE,NORMAL

New value: (1:NORMAL 2:HIGH 3:ULTRA HIGH) :

MEMORY ALLOC,IMAGE BUFF SIZE,48

New value: (0-9999) :

MEMORY ALLOC,REC BUF UART1,300

New value: (0-99999) :

MEMORY ALLOC,TRANS BUF UART1,300

New value: (0-99999) :

End of setup, enter QUIT (Q), or QUIT and SAVE (S)

Line Analyzer

The Line Analyzer (LINE_AXP.PRG) is a program written in the Intermec Fingerprint programming language and is intended to help solving possible communication problems. As the name implies, the Line Analyzer captures all incoming characters on a specified communication channel and prints them on one or more labels.

Printable characters are printed in black-on-white, whereas control characters and space characters (ASCII 000–032 dec) are printed in white-on-black.

While the printer is receiving data, the “Ready” control lamp blinks. There is a 0.5 second timeout. That is, if no more characters have been received after 0.5 second, the program considers the transmission terminated and prints out a label.

As long as a continuous string of characters is being received, the program wraps the lines until the label is full and then starts to print another label. At the bottom of each label, the following information is printed:

- Page number
- Number of characters printed on the label
- Total number of characters received so far

The Line Analyzer is displayed as the option “LINE_ALY.PRG” under the “SEL. APPLICATION” menu. After the Line Analyzer has been selected and the printer has started up again, the printer feeds out two labels and the following menu is displayed:

```
Line Analyzer
Sel.port(1-4) 1
```

Enter the desired communication port using the numeric keys on the printer’s keyboard:

```
1 = "uart1:"
2 = "uart2:"      (not available for EasyCoder 501 S)
3 = "uart3:"      (not available for EasyCoder 501 S)
4 = "centronics"
```

If the printer is not fitted with the specified port, an error message appears in the display and you can select another port:

```
Line Analyzer
Error:56
```

Options

Introduction

The EasyCoder 501 S provides a high degree of flexibility because it has a modular design. By adding options to the basic printer, the EasyCoder 501 S can be adapted for a variety of applications. Most options can easily be installed by the operator, however a few should be installed by an authorized service technician or are only available as factory-installed options.

Cutter

The cutter unit is fitted on the same hinges as the front door, which it replaces, and is connected by a single cable to the DIN-connector on the printer's front.

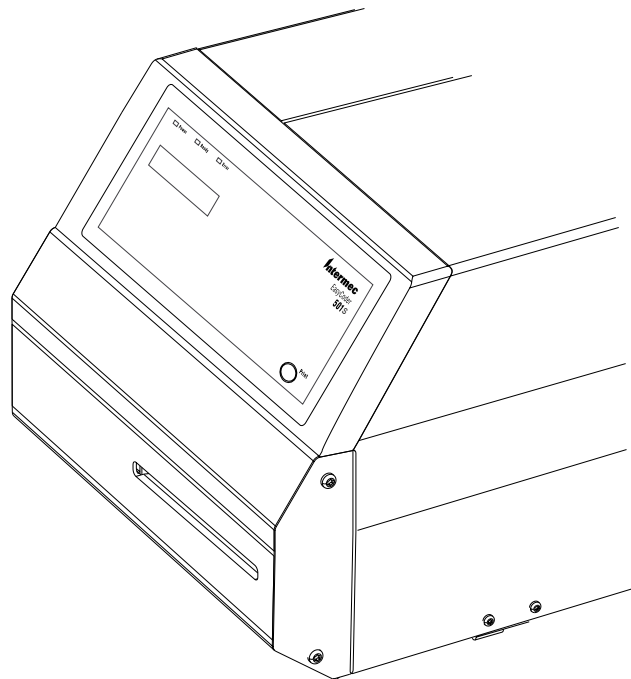

The cutter is intended to cut through continuous non-adhesive paper strip or through the liner between labels. It must not cut through any kind of adhesive, which would stick to the cutting parts and rapidly render the cutter inoperable or even damage the electric motor. Maximum thickness is 175 μm (175 grammes/m²) for paper-based materials.

The cutter **increases** the printer's total weight by approx. 1.0 kg (=2.2 lbs) and its length by 28 mm (1.1 inches).

Cutter, cont.

The cutter can be tilted forward in order to facilitate cleaning and media load.

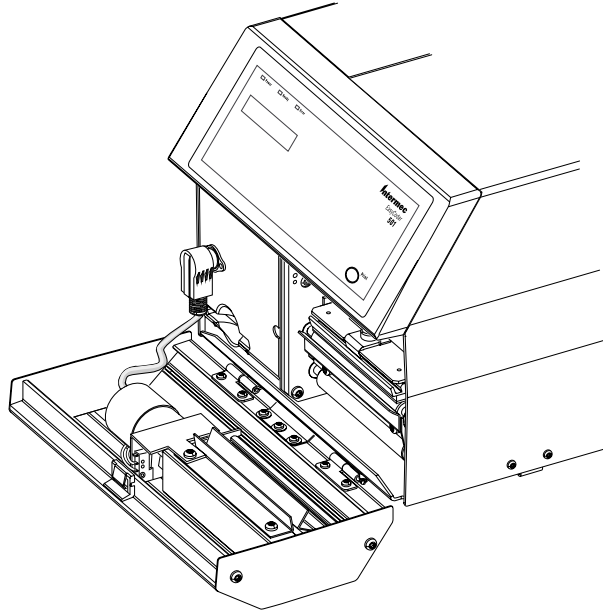

The cutter is activated by CUT or CUT ON instructions, see *Intermec Fingerprint v6.14, Reference Manual* or *Intermec Direct Protocol, v6.13, Programmer's Guide*.

For more information on how to adapt the media feed for cut-off operation, refer to Chapter 7 in this manual.

Warning!

The cutter has sharp cutting parts, that may be activated unexpectedly, for example at power on and reboot. For safety reasons, the power to the printer should always be switched off before the cutter is opened. Keep fingers away from cutting parts.

Memory Card Adapter

The EasyCoder 501 S can be equipped with an **optional** memory card adapter inside the front door.

Memory Card Types

The printer's Read-Only Memory ("rom:") or Random Access Memory ("ram:") can be supplemented by memory cards complying with the JEIDA-4 standard and with a maximum size of 2 Mbytes.

Non DOS-formatted memory cards are available in two types, OTPROM (One-Time Programmable Read-Only Memory) or SRAM (Static Random Access Memory), each in several sizes in regard of memory capacity, see below.

- OTPROM cards can only be read by the Intermec Fingerprint firmware after being preprogrammed using for example the Intermec Configuration program. Once programmed, they cannot be reprogrammed.
- SRAM cards may be used the same way as OTPROM cards. The files in such a card are regarded as an integrated part of the printer's ROM memory and can be listed using the statement FILES "rom:".

DOS formatted memory cards are always of SRAM-type and can both be read from and written to, that is, they will work almost like a floppy disk. Files in a DOS-formatted card are addressed by adding "card1:" in front of the name of the file. The statement FILES "card1:" lists all files in the currently inserted card. Unformatted SRAM cards can be DOS-formatted in the printer using the FORMAT statement.

All SRAM memory cards require internal 3V lithium batteries (coin type) to retain their content. Note that there is no consumption of battery voltage as long as the card is inserted in a switched-on printer. A few minutes are allowed for battery replacement without any loss of data. Refer to the manufacturer's specifications.

Memory Card Adapter, cont.

Important!

The printer must be OFF when the memory card is inserted or removed.

Fitting a Memory Card

- Switch off the power to the printer and open the front door.
- In case of non DOS-formatted memory card, check that the protection switch is set to *Write Protect*. (The location of the switch varies between different brands.) This does not apply to DOS-formatted memory cards!

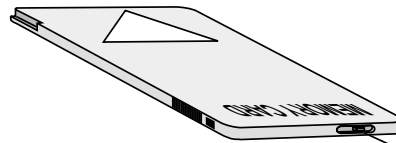

Protection Switch

- Insert the memory card into its adapter as illustrated below. Make sure that the manufacturer's logotype on the memory card is facing upwards.

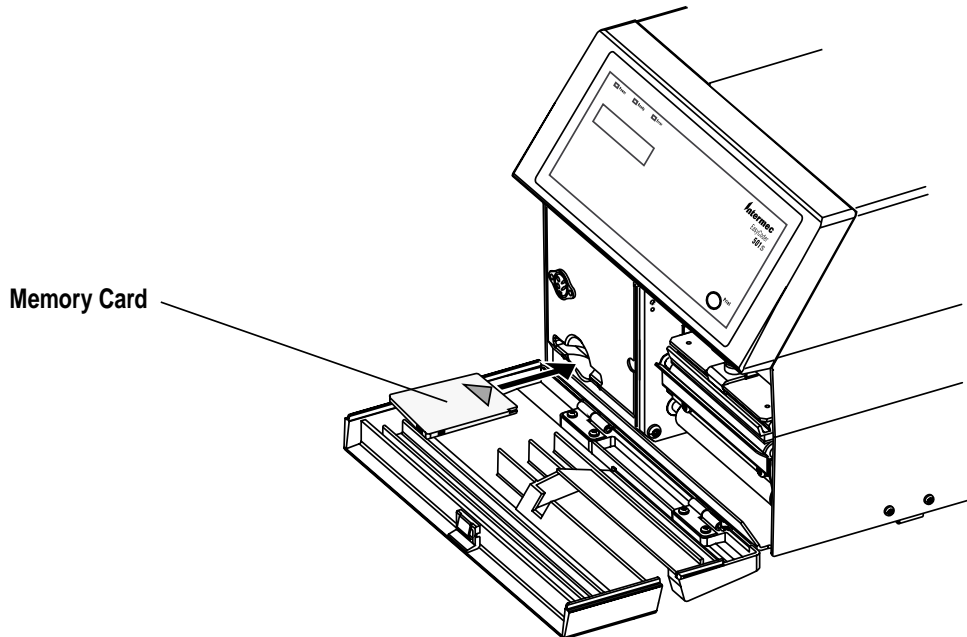

Memory Card

- Press firmly inwards so the pins in the adapter engage the corresponding slots in the memory card.
- Switch on the power again and close the front door.

Removing a Memory Card

- Before removing the memory card, switch off the power.
- Open the front door and pull the card straight out.
- Close the front door and switch on the power again.

Liner Takeup Unit

The liner takeup unit separates self-adhesive labels from the liner and winds up the liner on an integral takeup hub. See illustrations in Chapter 3, “Installation/Media Compartment” and Chapter 5, “Media Load/Peel-Off.”

Internal Batch Takeup Guide

The internal batch takeup guide is used to wind up printed labels or similar inside the printer for later use, for example for manual application. It requires a liner takeup unit (see above). The internal batch takeup guide is fitted instead of the standard tear bar at the front of the print unit. Refer to Chapter 5, “Media Load/Internal Batch Takeup” for illustrations.

Media Roll Retainer

The media roll retainer holds the media roll in place when the printer is not placed on a horizontal surface or when a slippery liner makes the label roll come apart sideways. The media roll retainer is pressed onto the media supply hub after the media roll has been loaded. Refer to Chapter 3, “Installation/Media Compartment” for illustration.

External Media Guides

The external media guides helps to keep the media properly aligned when an external media supply behind the printer is used, for example a box of fan-folded tickets. The external media guides can be fitted to either the upper or lower slot in the printer’s rear plate. The outer guide can be adjusted for various media widths. Refer to Chapter 3, “Installation/External Supply” for illustrations.

Scaleable Fonts Kit

Introduction

EasyCoder 501 S can be fitted with an optional firmware package, that allows the printer to use scaleable outline fonts in Speedo and TrueType formats.

Speedo and TrueType are standard outline font formats for personal computers developed by Bitstream, Inc. and Apple Computer, Inc. respectively. There are thousands of different fonts available from Intermec at a low cost. The fonts come as files in PC format and can be downloaded to the printer via the Kermit communication protocol (see later in this chapter) or be copied to a memory card, which is inserted in the printer's optional memory card adapter.

Scaling Fonts in Intermec Fingerprint

The Intermec Fingerprint statement FONT converts the selected outline font according to the specified characteristics to Intermec's bitmap font format, after which it can be used as any other installed bitmap font (also see FONT statement in *Intermec Fingerprint v6.14, Reference Manual*).

The outline font can be converted in regard of:

- Name
- Size
- Range of characters
- Direction
- Slanting
- Rotation
- Character map table

After the conversion the bitmap font may either be saved in the battery backed-up part of the RAM memory or in a no-save area (that is, the bitmap font will be erased at power-off).

Scaleable Fonts Kit, cont.

Downloading Outline Font Files from a PC

Scaleable outline font files come in PC format. Using a personal computer, such font files can be downloaded to the RAM memory of the printer. The following description applies to the Terminal program in Microsoft Windows, but similar methods can be used with other communication programs that support Kermit.

- Break any program running in the printer, for example by pressing the <C> and <Pause> keys. The printer should be in the Immediate Mode of Intermec Fingerprint.
- Set up the printer and the computer for RS-232 with the same communication parameters and connect the computer to the communication port "uart1:" of the printer.
- Check that the communication works both ways by typing for example **BEEP** on the computer. The printer should respond by emitting a short beeping sound and return **Ok** to the computer's screen.

- Set up the printer to receive a file by typing:

TRANSFER K "R" ↵

For more information, refer to the TRANSFER KERMIT statement in the *Intermec Fingerprint v6.14, Reference Manual*.

- In the Terminal program, select:
Settings\Binary Transfer\Kermit.
- Start the transfer of the file by selecting:
Transfers\Send Binary File.
- Select the scaleable outline font file you want to transfer, for example **BX000003.SPD.**
- At the bottom of the window, the progress of the transfer is shown. Downloading will take a minute or so, depending on the size of the file.

Scaleable Fonts Kit, cont.

Printout Samples

The following 10 scaleable outline fonts in Speedo format are stored in the EPROMs of the Scaleable Fonts Kit. All characters from ASCII 32 through 254 decimal according to the Roman 8 character set are included.

Intermec0003.SPD Bitstream Swiss 721 0003 Roman	THE QUICK BROWN FOX JUMPS OVER THE LAZY DOG the quick brown fox jumps over the lazy dog 012345
Intermec0005.SPD Bitstream Swiss 721 0005 Bold	THE QUICK BROWN FOX JUMPS OVER THE LAZY DOG the quick brown fox jumps over the lazy dog 012345
Intermec0010.SPD Bitstream Swiss 721 0010 Bold Condensed	THE QUICK BROWN FOX JUMPS OVER THE LAZY DOG the quick brown fox jumps over the lazy dog 012345
Intermec0011.SPD Bitstream Dutch 801 0011 Roman	THE QUICK BROWN FOX JUMPS OVER THE LAZY DOG the quick brown fox jumps over the lazy dog 012345
Intermec0013.SPD Bitstream Dutch 801 0013 Bold	THE QUICK BROWN FOX JUMPS OVER THE LAZY DOG the quick brown fox jumps over the lazy dog 012345
Intermec0138.SPD Bitstream Futura 0138 Light	THE QUICK BROWN FOX JUMPS OVER THE LAZY DOG the quick brown fox jumps over the lazy dog 012345
Intermec0414.SPD Bitstream Letter Gothic 12 Pitch 0414 Roman Fixed Spacing	THE QUICK BROWN FOX JUMPS OVER THE LAZY DOG the quick brown fox jumps over the lazy dog 012345
Intermec0596.SPD Bitstream Monospace 821 0596 Roman Fixed Spacing	THE QUICK BROWN FOX JUMPS OVER THE LAZY DOG the quick brown fox jumps over the lazy dog
Intermec0598.SPD Bitstream Monospace 821 0598 Bold Fixed Spacing	THE QUICK BROWN FOX JUMPS OVER THE LAZY DOG the quick brown fox jumps over the lazy dog
Intermec0959.SPD Bitstream Zurich 0959 Extra Condensed	THE QUICK BROWN FOX JUMPS OVER THE LAZY DOG the quick brown fox jumps over the lazy dog 012345

Clear Door Panel

As standard, the EasyCoder 501 S is fitted with a solid door on its right side. This door can easily be replaced by a door with a clear panel that makes it possible to check the media supply without opening the door.

Remove the existing door by opening it and pressing it forward until the snap-lock at the rear hinges becomes disengaged. Remove the door from the hinges and fit the new door in reverse order.

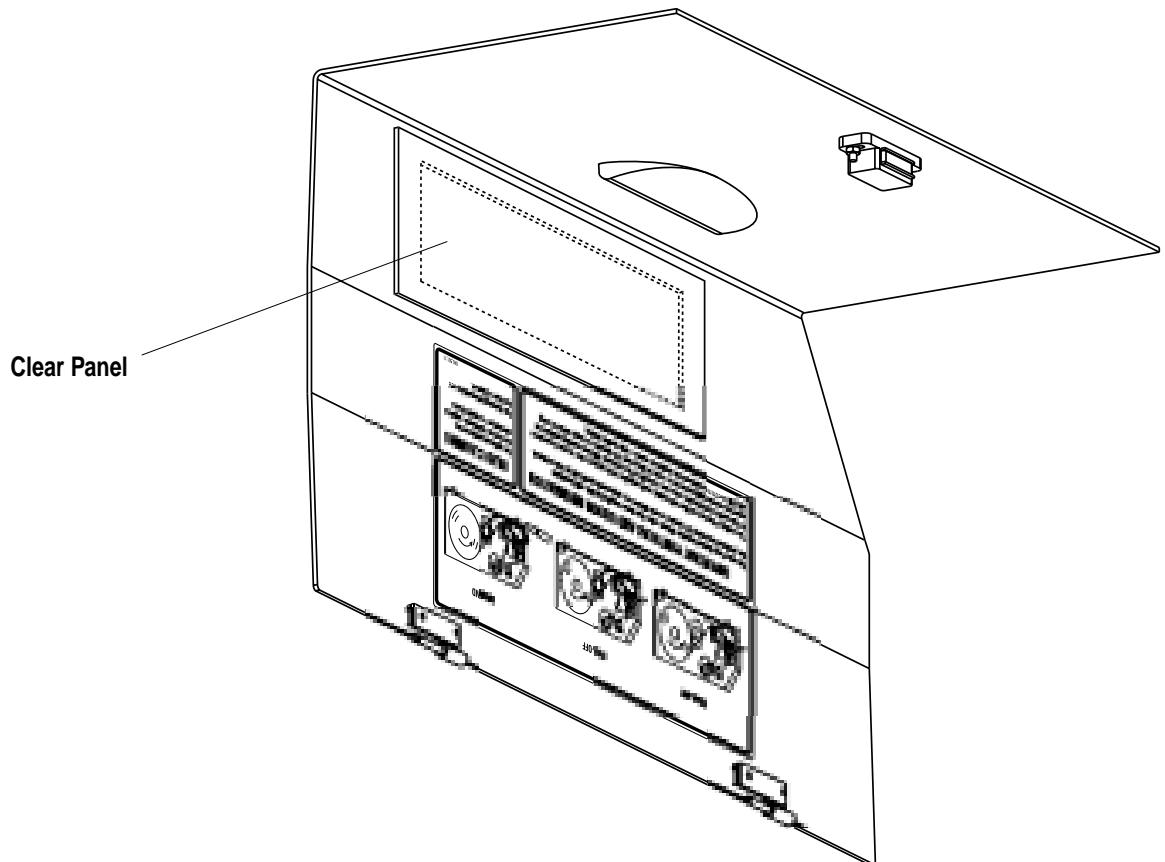

Interface Boards

The EasyCoder 501 S has one serial interface port ("uart1:"), see Appendix 4. In addition to this port, the printer can be fitted with the following optional interface board:

- **Parallel Interface Board**
1 × Centronics

Please refer to Appendix 4 for more information.

Troubleshooting

Symptom	Possible Cause	Remedy	Refer to
Overall weak printout	Wrong Paper Type parameter Contrast value too low Printhead pressure too low Worn printhead Wrong printhead voltage	Change parameter Change parameter Adjust both knobs Replace printhead Replace CPU board	Chapter 7 Chapter 7 Chapter 13 Chapter 12 ☛ Call Service
Printout weaker on one side	Uneven printhead pressure	Adjust outer knob	Chapter 13
Weak spots	Foreign particles on media or ribbon Media/ribbon don't match Poor media or ribbon quality Worn printhead Worn platen roller	Clean or replace Change to matching media Use Intermec media/ribbon Replace printhead Check/replace	Chapters 5 & 6 Chapter 7 Appendix 2 Chapter 12 ☛ Call Service
Overall dark printout	Wrong Paper Type parameter Contrast value too high Printhead pressure too high Wrong printhead voltage	Change parameter Change parameter Adjust Replace CPU board	Chapter 7 Chapter 7 Chapter 13 ☛ Call Service
Excessive bleeding	Wrong Paper Type Contrast value too high Printhead pressure too high Faulty energy control	Change parameter Change parameter Adjust both knobs Replace CPU board	Chapter 7 Chapter 7 Chapter 13 ☛ Call Service
Dark lines along media path	Foreign objects on printhead	Clean printhead	Chapter 12
White lines along media path	Printhead dirty Missing dots on printhead	Clean printhead Replace printhead	Chapter 12 Chapter 12
Large part of dot line missing	Wrong X-start or Width parameter Failing printhead Failing strobe signal	Change parameter Replace printhead Check CPU-board	Chapter 7 Chapter 12 ☛ Call Service
Last part of print image missing	Too small image buffer	Increase buffer size	Chapter 7
Printout missing along inner edge	Bad media alignment X-start parameter value too low	Adjust Increase	Chapter 5 Chapter 7
Transfer ribbon breaks	Ribbon not fitted correctly Wrong paper type parameter (too much energy) Ribbon supply hub stuck Bad energy control	Reload ribbon Change parameter, then clean printhead Adjust Adjust	Chapter 6 Chapter 7 Chapter 13 ☛ Call Service ☛ Call Service
Transfer ribbon wrinkles	Ribbon supply hub not centered Ribbon obstructed by printhead cable Incorrect edge guide adjustment Too strong printhead pressure	Adjust Clear Adjust Adjust	Chapter 13 n.a. Chapter 5 Chapter 13
No thermal transfer printout	Ink-coated side does not face media	Reload ribbon	Chapter 6
Media feed not working properly	Changed media characteristics Wrong start- and stop adjust values Wrong Media Type parameter Wrong sensor position Dirty or blocked LSS Faulty sensors	Perform a TESTFEED Check/change Check/change Check/change Clean Replace	Chapter 5 Chapter 7 Chapter 7 Chapter 13 Chapter 12 ☛ Call Service

Maintenance

Printhead Cleaning

Cleaning the printhead on a regular basis is important for the life of the printhead and for the printout quality. You should clean the printhead each time you replace the media. This section describes how to clean the printhead using cleaning cards. If additional cleaning is required, for example removing adhesive residue from the platen roller or tear bar, use a cotton swab moistened with isopropyl alcohol.

Warning!

Isopropyl alcohol [(CH₃)₂CHOH; CAS 67-63-0] is a highly flammable, moderately toxic, and mildly irritating substance.

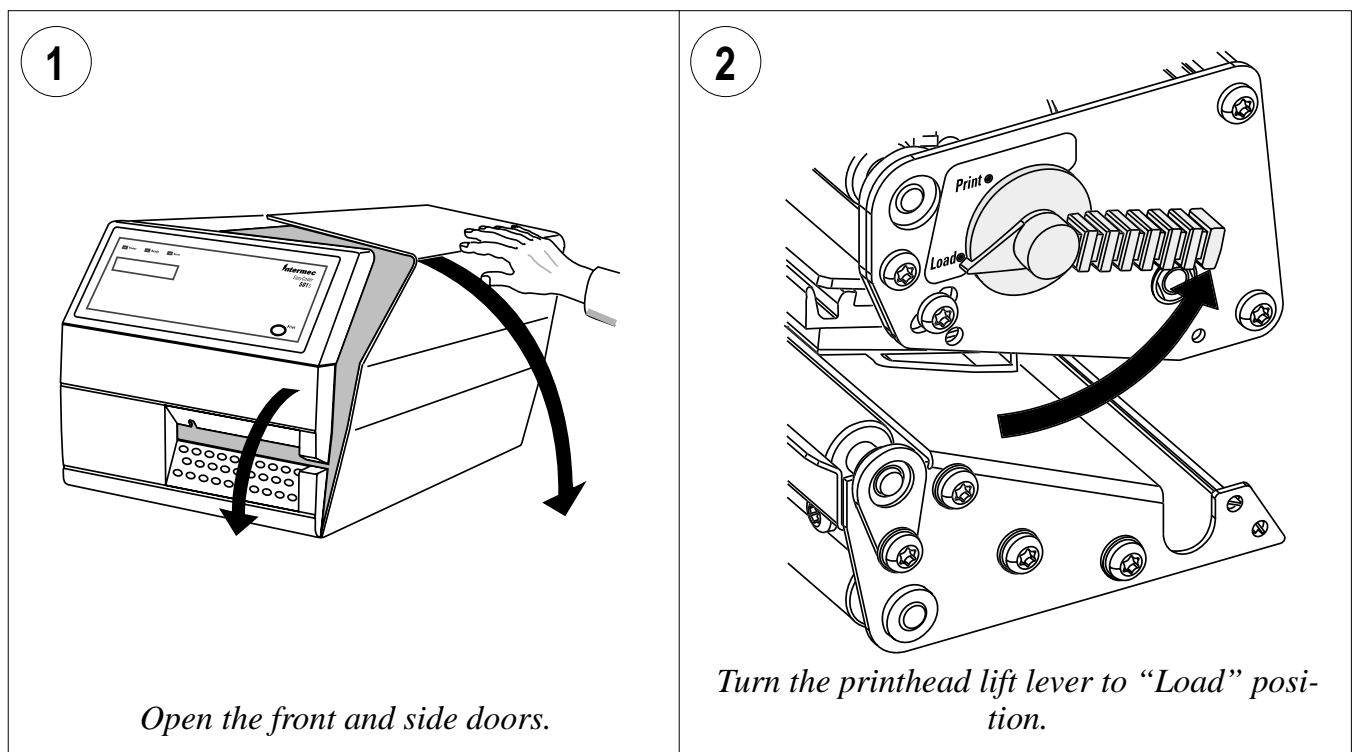

Printhead Cleaning, cont.

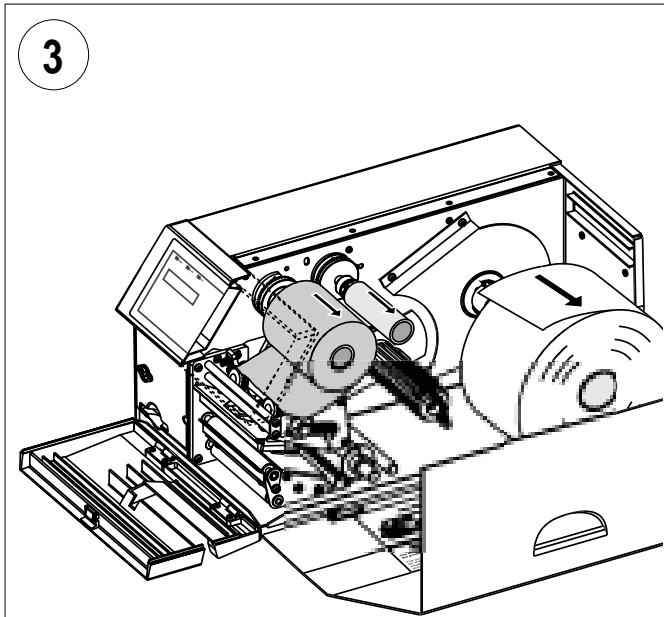

Remove any media and ribbon supply.

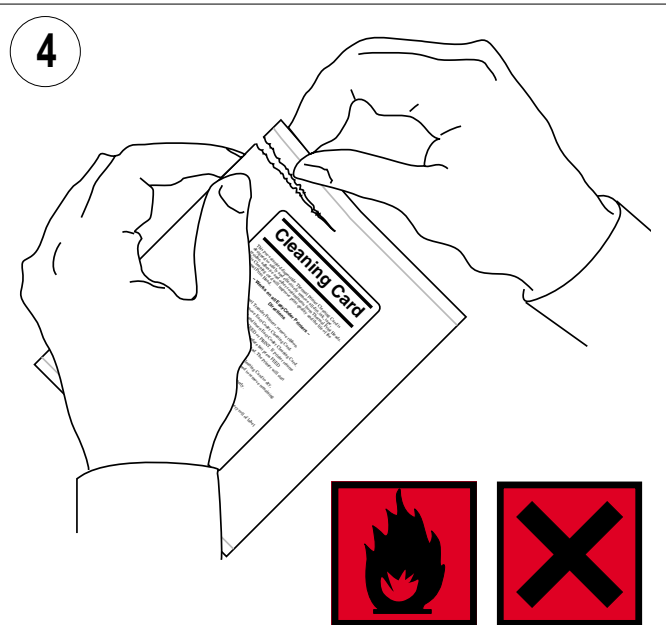

Open the cleaning card envelope and pull out the cleaning card. Read the warning text.

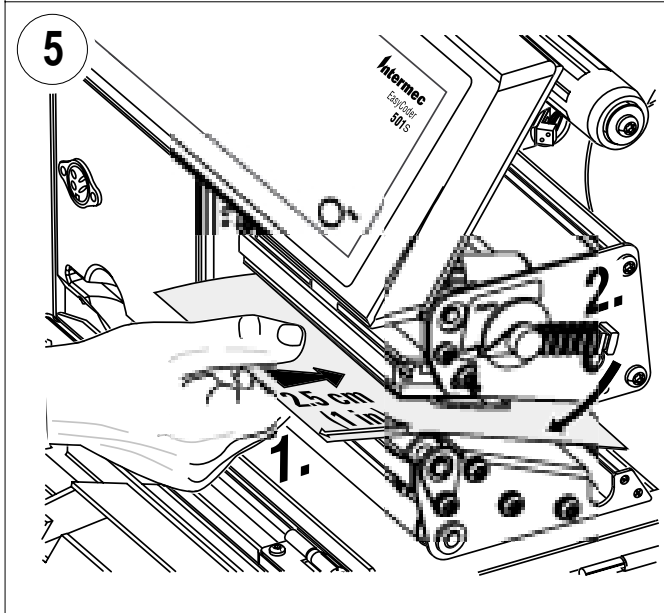

Insert most of the cleaning card under the printhead (1). Engage the printhead (2).

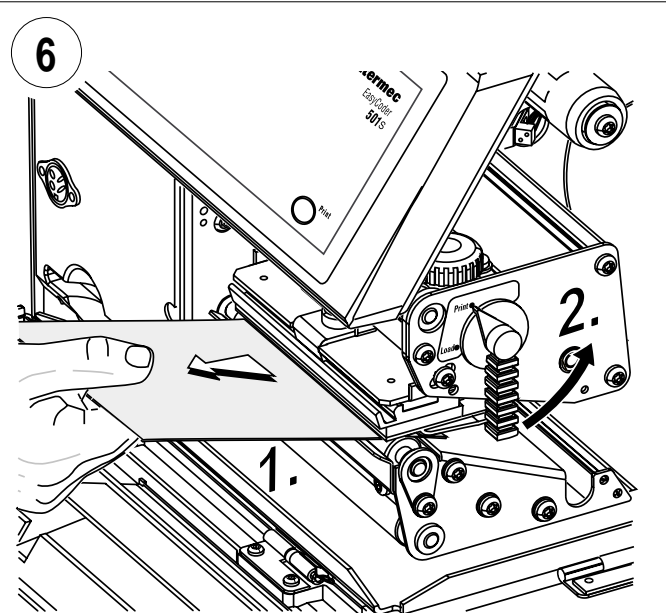

Pull out the cleaning card (1) and raise the printhead (2).

Printhead Cleaning, cont.

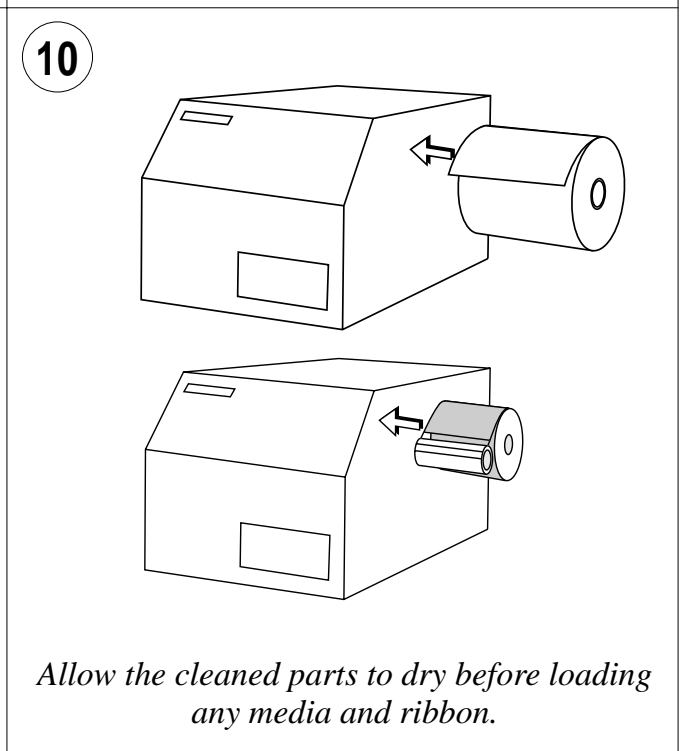
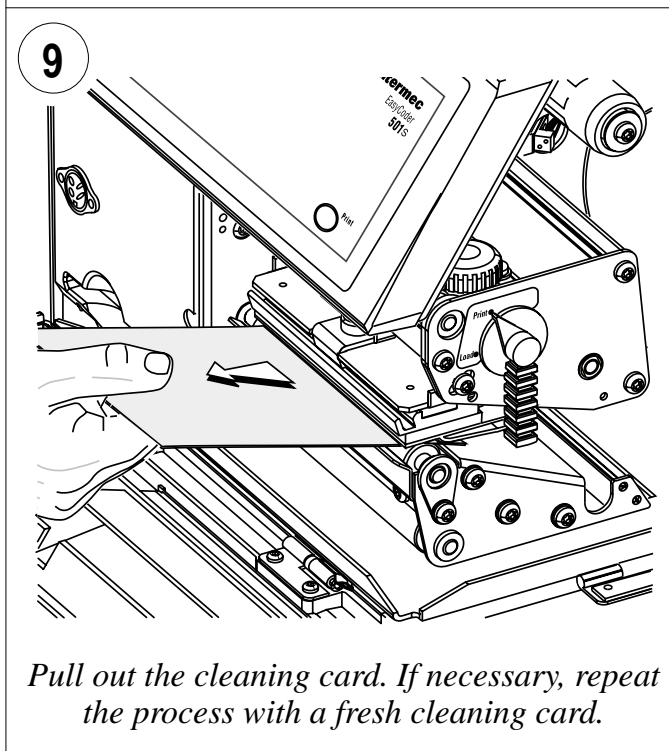
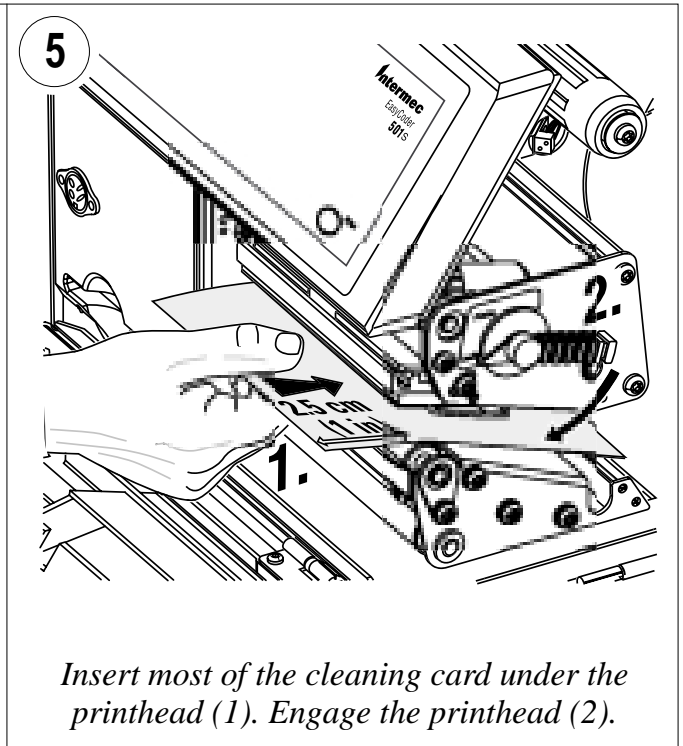
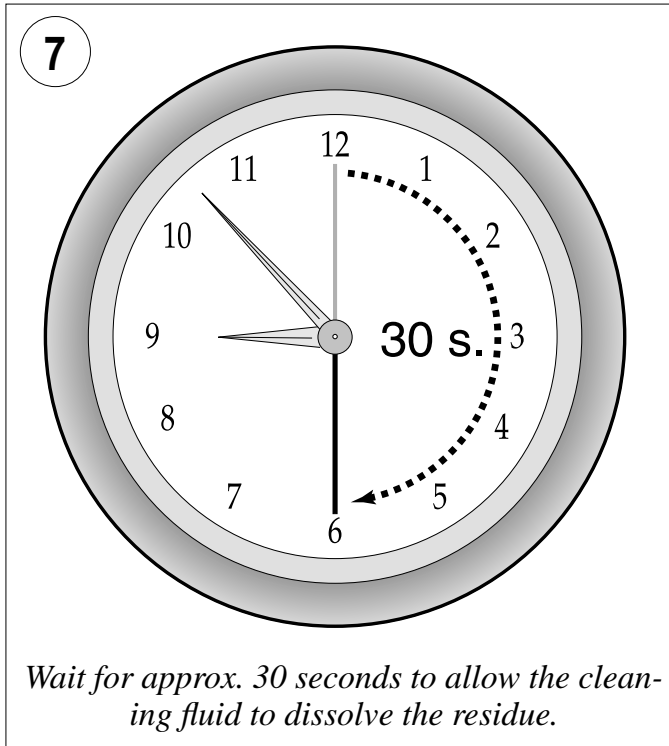

External Cleaning

1

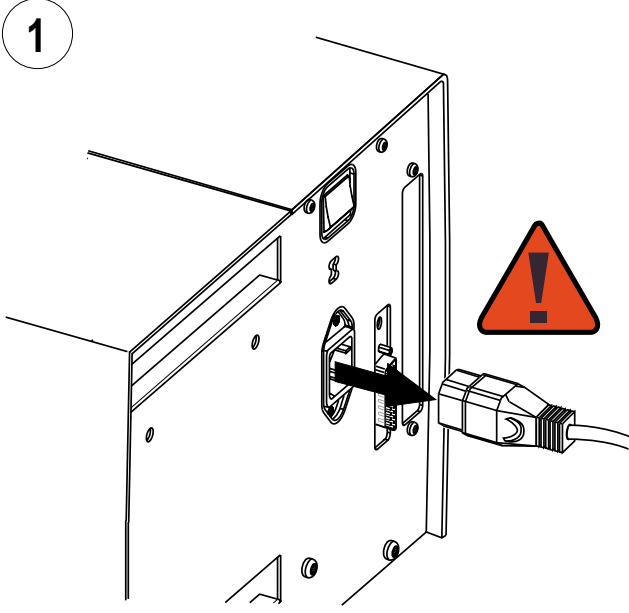

Always remove the power cord before cleaning!

2

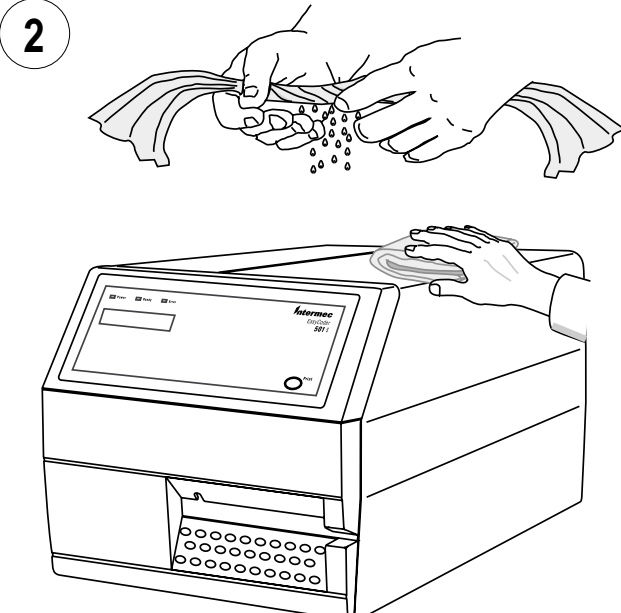

Wipe external surfaces with a soft cloth slightly moistened with water or a mild detergent.

3

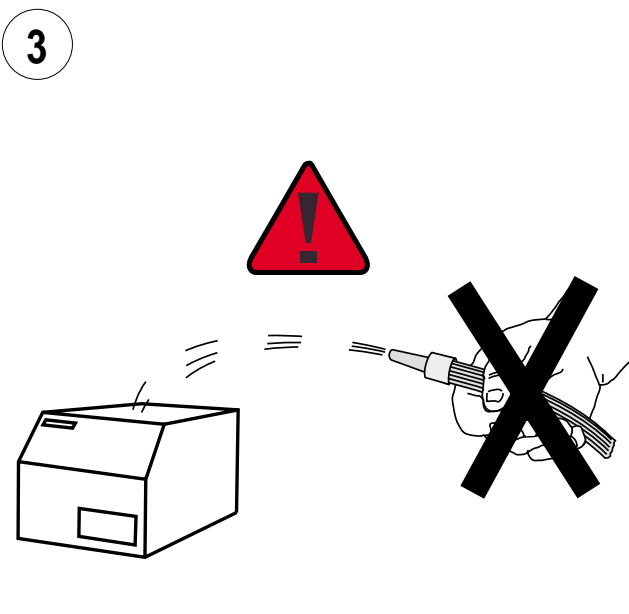

Never spray the printer. Protect it from water when cleaning the premises.

4

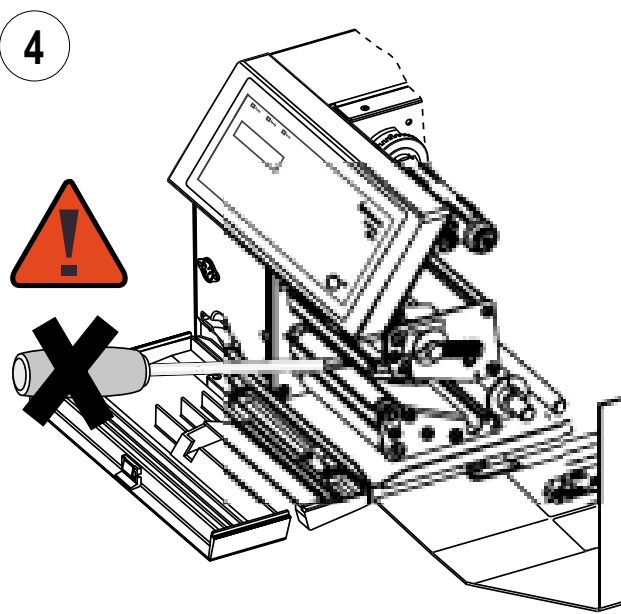

Never use any sharp tools for removing stuck labels. The printhead and rollers are delicate.

Cleaning the Cutter (option)

Warning!

Isopropyl alcohol [(CH₃)₂CHOH; CAS 67-63-0] is a highly flammable, moderately toxic, and mildly irritating substance.

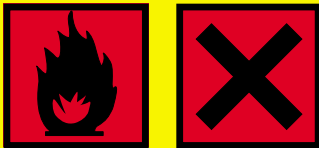

The cutter mechanism consists of a rotating shear and a spring-loaded anvil blade. When cutting self-adhesive media stock between labels, regular cleaning from adhesive residue at the cutting edge of the anvil blade is essential for troublefree operation. Proceed as follows:

- Switch off the power to the printer to prevent the cutter from being accidentally activated during cleaning.
- Fold down the cutter.
- Soak a cotton swab with isopropyl alcohol and rub it against the cutting edge of the anvil blade to dissolve any adhesive residue.
- Inspect the interior of the cutter for possible shreds of labels, adhesive residue and similar. If necessary, clean using a cleaning card or a cotton swab soaked with isopropyl alcohol.
- Allow the cleaned parts to dry for a few minutes.
- Fold up the cutter and switch on the power.

Caution!

Do not force the spring-loaded anvil blade open, or the spring may be weakened.

Anvil Blade

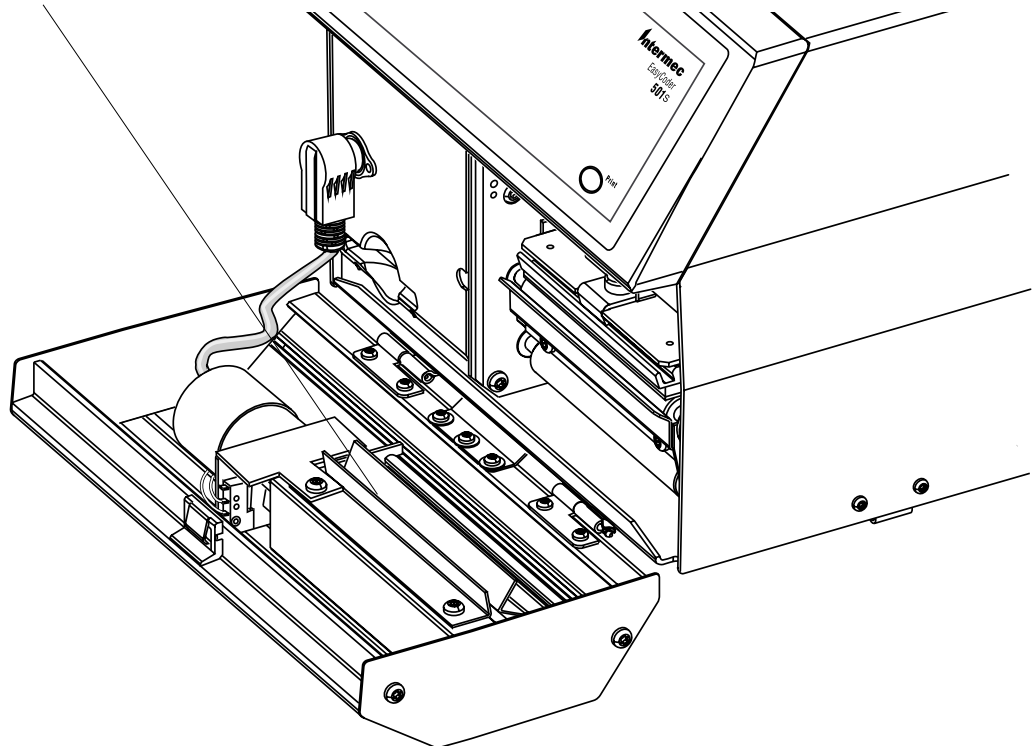

Printhead Replacement

The quick-mount thermal printhead is easy to replace:

- Switch off the printer.
- Open the front and right-hand doors.
- Lift the printhead and remove the media.
- Rotate the printhead lock handle counterclockwise to **open** position, see illustration.
- Remove the printhead assembly carefully as far as the cables allow.
- Remove the two printhead cables by pulling at the connectors.
- If you want to change the lateral position of the printhead, move the #T20 Torx screw to its alternative position.
- Connect the two cables to the printhead.
- Fit the replacement printhead assy back into the bracket so the guide screw fits into its slot and the rear end of the assy is held by the two lugs.
- Rotate the locking handle clockwise to **locked** position.
- Load media. Then engage the printhead.
- Switch on the power. At power-up, the printer will automatically reset itself to the characteristics of the printhead in regard of head resistance.

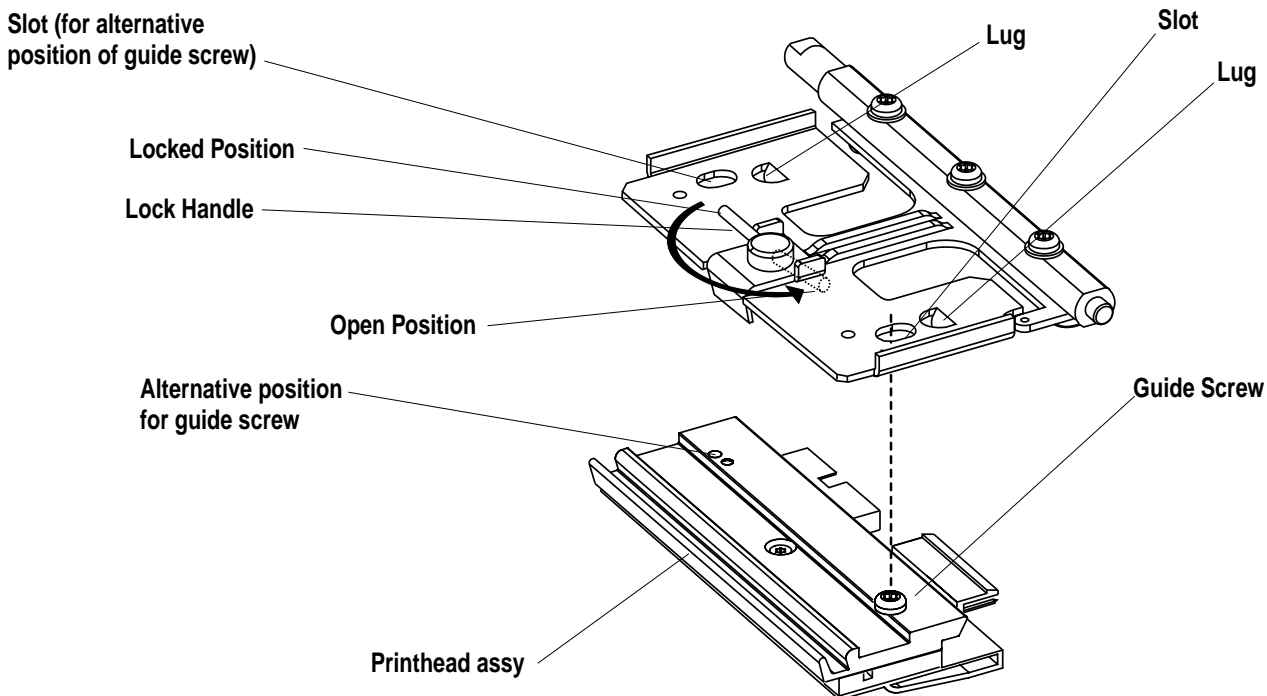

Adjustments

Label Stop Sensor

Position Adjustment

The label stop sensor (LSS) controls the media feed by detecting gap between labels, slots in continuous stock, or black marks at the back of continuous stock. Also see Chapter 7, “Setting Up the Printer.”

The label stop sensor can be moved sideways across the media path. The position can be changed continuously from the inner edge of the media and up to 50 mm (1.97 inches) outwards. The inner edge of the handle indicates the detection position. Always adjust the position of the LSS so it corresponds to the center of black marks or slots. In case of irregularly shaped labels, adjust the position so it corresponds to the front tip of the label.

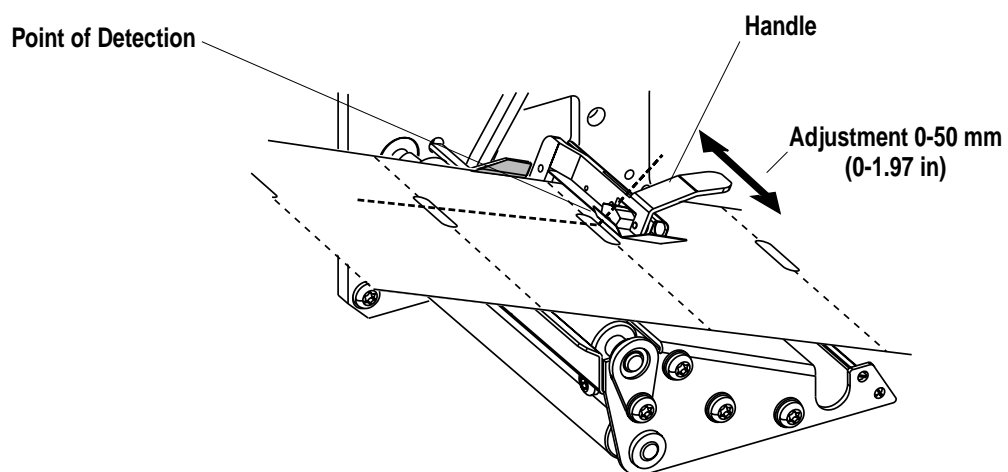

Label Stop Sensor, cont.

Sensitivity Adjustment

The sensitivity of the label stop sensor can be adjusted in three ways:

- Fine-adjustment can be performed by pressing the <**Feed**> key, by using a Testfeed operation in Intermec Shell (see Chapter 9) or by executing a TESTFEED statement (see *Intermec Fingerprint v6.14, Reference Manual* or *Intermec Direct Protocol v6.13, Programmer's Guide*).
- The intensity of the LSS emitter can be adjusted in the Setup part of Intermec Shell Standard (see later in this chapter) or using setup files (see *Intermec Fingerprint v6.14, Reference Manual*).
- The sensitivity of the LSS receiver can be adjusted using a potentiometer on the CPU board, see Appendix 3.

Adjusting the LSS in the Setup part of Intermec Shell

The intensity of the LSS emitter can be adjusted in the Setup part of Intermec Shell Standard:

```
SHELL
SETUP
```

Press <**Print**> with the printhead lowered.

```
HU/PP: SET
HD/PP: VIEW
```

Lift the printhead and press <**Print**>.

```
LSS ADJUST
```

Press <**Print**> without moving the printhead.

```
LABEL <103> GAP
      ■
```

- Often it will suffice just to perform a couple of TESTFEED operations, which allows the printer to auto-adjust itself. Without pressing >Print>, **lower and lift** the printhead. A blank label (or the equivalent) will be fed out. When the media feed works as expected, you can exit the LSS adjustment by lowering the printhead and pressing <**Print**>, which will take you to the part where you can view all other setup parameters.

Label Stop Sensor, cont.

- If you cannot make the media feed work properly using TEST-FEEDs, you will have to adjust the LSS as described below. Before the LSS is adjusted, the printer must be set for the type of media you intend to use, that is, *Label (w gaps)*, *Ticket (w mark)*, *Ticket (w gaps)*, *Fix length strip*, or *Var. length strip*.

Label (w gaps)

Put a piece of labels with liner between the two parts of the sensor. The cursor should appear at the left side of the menu:

```
LABEL <103> GAP
■
```

Put a piece of liner without any label into the sensor. The cursor should move to the center of the menu:

```
LABEL <103> GAP
      ■
```

Finally remove any from the sensor. The cursor should move to the right side of the menu:

```
LABEL <103> GAP
                ■
```

Ticket (w mark)

Put the media between the two parts of the sensor, making sure there is no black mark close to the LSS. The cursor should appear at the right side of the menu:

```
MARK <103>TICKET
                ■
```

Move the media so the black mark becomes situated above the sensor. The cursor should move to the left side of the menu (the same applies when no media is loaded):

```
MARK <103>TICKET
■
```

Ticket (w gaps), Fix Length Strip, and Var. Length Strip

Put the media between the two parts of the sensor, making sure there is no gap close to the LSS. The cursor should appear at the left side of the menu:

```
LABEL <103> GAP
■
```

Label Stop Sensor, cont.

- ❑ *Ticket (w gaps), Fix Length Strip, and Var. Length Strip, cont.*

In case of tickets, move the media so the gap becomes situated above the sensor. In case of strip, remove the media completely.

In both cases, the cursor should move to the left side of the menu:

LABEL <103>	GAP
	■

- ❑ If the cursor is not situated correctly, the LSS must be adjusted.
 - The LSS emitter can be set to a value between 0 and 127. With the printhead lifted, press <**Print**>. Each time you press <**Print**> the value will be increased by 8 steps in an endless loop (0-7-15-23-31.....-119-127-0-7.....) Keep trying until you find the right level.
 - When the adjustment looks right, **lower and lift** the printhead. This will produce a TESTFEED, that is, it will allow the printer feed out one label, ticket, tag, or piece of strip in order to adjust itself and to allow you to check that the media feed works correctly. At least two TESTFEEDs should be produced before you go on.
 - If you cannot make the LSS work correctly by following the instructions above, you may—as a last resort—need to adjust the potentiometer on the CPU board, see Appendix 3. Read the instructions carefully before starting, since you will be working in a part of the printer with live high-voltage components!
 - Try different combinations of potentiometer settings and LSS levels until the cursor is positioned correctly.
 - When you are satisfied that the LSS is set up correctly, lower the printhead and press <**Print**>. That will set the LSS and take you to the part where you can view all setup parameters.
 - To exit to the main part of the Intermec Shell Standard program, lift the printhead and press <**Print**>.

Display Contrast

The contrast of the printer's display can be adjusted using a potentiometer, which is situated close to the connector of "uart1:". It can be accessed through a small hole in the rear plate. Using a narrow-tipped screwdriver, turn the screw in either direction until the text in the LCD display on the printer's front becomes clearly visible in the prevailing light conditions when viewed from a normal working position.

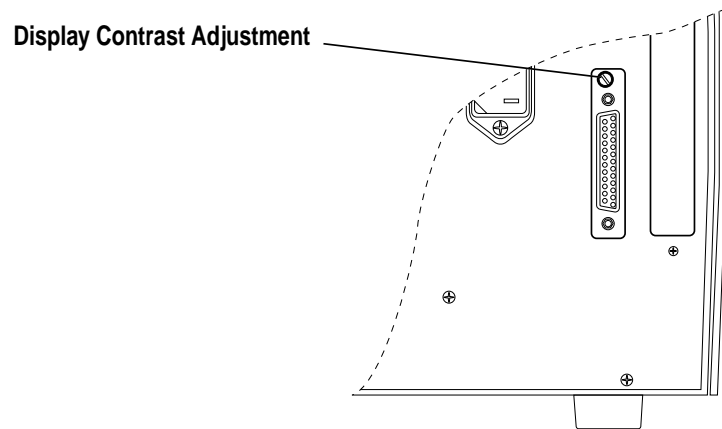

Printhead Pressure

At printing, the thermal printhead must be pressed against the platen roller so the heat can be transferred to the media. There must also be enough pressure to provide a sufficient amount of friction between the media and the platen roller that drives the media. Too weak pressure gives a weak printout quality, whereas too strong pressure may cause unnecessary wear of the printhead.

The pressure is factory adjusted, but special applications may require readjustment using the trial-and-error method. Do not use more pressure than necessary to obtain the desired printout quality.

The print unit is fitted with two adjustable spring packages, which allow the pressure to be set by turning the knobs:

- Turn the knobs clockwise to increase the pressure.
- Turn the knobs counter-clockwise to decrease the pressure.

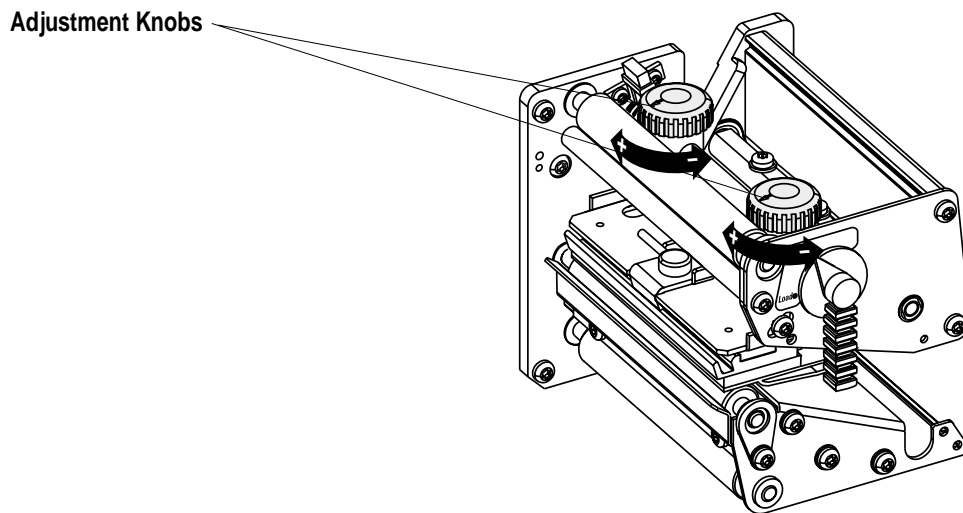

At each quarter of a turn, the resistance increases and a clicking sound can be heard.

The required pressure may vary between media of different thickness. Generally, thicker media require more pressure than thinner.

Make a **rough** adjustment like this:

- Turn **both** adjustment knobs clockwise as far as they go to maximum pressure.
- Release the pressure of the **inner** spring package by turning the knob $2\frac{1}{4}$ turns counter-clockwise (9 clicks).
- Release the pressure of the **outer** spring package by turning the knob 2 turns counter-clockwise (8 clicks).

Fine-adjust the pressure by turning the outer knob, while retaining the setting of the inner knob. If the desired result cannot be obtained, increase or decrease the pressure by turning both knobs a quarter of a turn in the same direction, then fine-adjust the outer knob.

Technical Data

Printing		
Print Technique	Direct Thermal and Thermal Transfer ¹	
Printhead Resolution	8 or 11.81 dots/mm (203.2 or 300 dpi)	Quick-mount printhead
Print Speed (max)	75 to 100 mm/sec. (\approx 3 to 4 inches/sec.)	
Print Width (8/11.81 dots/mm), max.	104 mm (4.09 inches)/108.3 mm (4.26 inches)	= 832/1280 dots
Print Length (8/11.81 dots/mm)	1,250 mm (49.2 inches)/833 mm (32.8 inches)	
Media Width (max)	120 mm (4.7 inches)	
Media Roll Diameter (max)	205 mm (8.0 inches)	Internal roll
Media Roll Core Diameter	38 to 40 mm (1.5 inches) or 76 mm (3 inches)	
Ribbon Length, max	450 m (1,476 ft.)	Intermec ribbons
Ribbon Width (max)	110 mm (4.3 inches)	
Print Directions	4	
Modes of Operation		
Tear-Off (Straight-through)	Yes	
Cut-Off	Option	With cutter
Peel-Off (Self-strip)	Option	With liner takeup
Internal Batch Takeup	Option	With liner takeup
Firmware		
Operating System	Intermec Fingerprint v6.14	Incl. Direct Protocol
Smooth Fonts	Option (requires Scaleable Fonts Kit)	
Built-in bitmap fonts (std)	10	Expandible 4 times
Built-in bar code symbologies (std)	32	
Startup Program (std)	Intermec Shell v4.01 Standard	
Physical Measures		
Dimensions (W x L x H)	275 x 480 x 239 mm (10.8 x 18.9 x 9.04 inches)	Without cutter
Weight (excluding media and options)	\approx 15.0 kg (33 pounds)	
Ambient Operating Temperature	+5°C to +40°C (+41°F to +104°F)	
Humidity	20 to 80% non-condensing	
Sound Emission Level	<60 dB(A)	
Electronics		
Microprocessor	32 bit RISC	
On-board RAM memory	Std. 512 Kbytes; Max. 2MB ¹	
Power Supply		
Input Voltage	115/230 VAC (+10%/-15%), 2.6/1.3A, 60/50 Hz	Manual switch
Maximum Power Consumption	300W	

Technical Data, cont.

Sensors		
Label Gap/Black Mark/Out of Media	Yes	Variable position
Ribbon End	Yes	
Printhead Lifted	Yes	
Controls		
Control Lamps	3	
Display	2 x 16 character LCD	
Keyboard	1 key membrane-switch type	
Beeper	Yes	
Data Interfaces		
Serial	1 x RS-232 (prepared for RS-422 ² or 20 mA CL ²)	
Connection for Parallel Interface Board	1	
Accessories and Options		
Paper Cutter	Option ²	
Memory Card Adapter	Option ²	
Parallel Interface Board	Option ²	
Liner Takeup Unit	Option ⁴	Incl. batch takeup guide
Media Roll Retainer	Option ³	
External Supply Guides	Option ³	
RS-232 Cable	Option ³	
Parallel Interface Cable	Option ³	
External Alphanumeric Keyboard	Option ³	
Scaleable Fonts Kit	Option ²	
Clear Door Panel	Option ²	For view of media roll
¹ / Pure direct thermal configuration is only available as a factory-installed option.		
² / Available as factory installed option or field-installable kit.		
³ / Field-installable option only.		
⁴ / Factory-installable option only.		

Media Specifications

Direct Thermal Media

Intermec offers two quality grades of **direct thermal** media for the EasyCoder printers:

- **Premium Quality:** Top-coated media with high demands on printout quality and resistance against moisture, plasticisers, and vegetable oils. Examples:
 - Thermal Top Board
 - Thermal Top
 - Thermal Top High Speed
 - Duratherm II,
 - Duratherm II Tag
 - Duratherm Ltg.
 - Duratherm IR
- **Economy Quality:** Non top-coated media with less resistance to moisture, plasticisers, and vegetable oils. In all other respects, it is equal to *Premium Quality*. Examples:
 - Thermal Eco
 - Thermal Eco Board

Thermal Transfer Media

Intermec offers **stock** labels for thermal transfer printing in a wide range of quality grades.

- **Uncoated papers** for economical high-volume printing to be used with GP/Basewax/Standard ribbons. Examples:
 - TTR Uncoated
- **Coated papers** with various coat-weight, smoothness, and gloss to be used with HP/Premium and GP/Basewax/Standard ribbons. Examples:
 - TTR Matte Coated
 - TTR Premium
 - TTR Premium Board
 - Duratran II
 - Duratran II Tag
- **Polyethylene plastics** with better resistance to water and many common chemicals than uncoated and coated papers. They can be use outdoors and offer good tear resistance. Most often used with HP/Premium ribbons. Examples:
 - TTR Polyethylene
 - TTR Gloss Polyethylene
 - Kimdura Tag
 - Kimdura Tag
 - Syntran
- **Polyesters** give high resistance to chemicals, heat, and mechanical abrasion with HR/Super Premium ribbons. Examples:
 - TTR High Gloss Polyester
 - Polyester

Media Roll Size

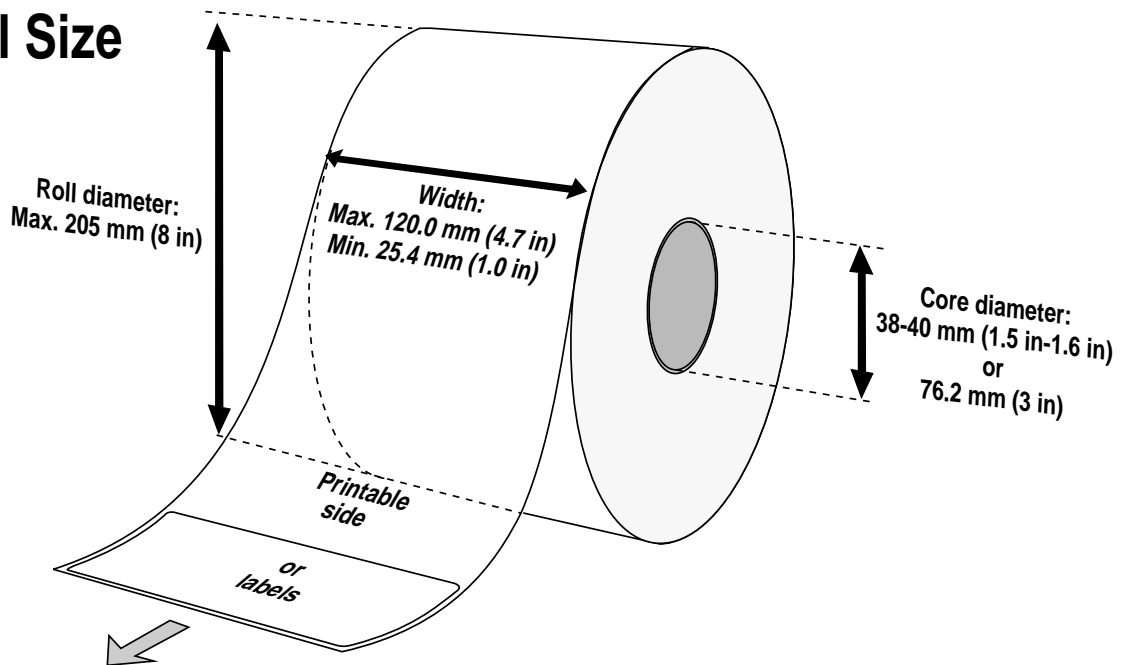

Core

Diameters: 38-40 mm (1.5 inches) or 76.2 mm (3 inches)
Width: Must not protrude outside the media.

The media must be wound up on the core in such a way that the printer can pull the end free.

Roll

Max. diameter (internal roll):	205 mm	(8.00 inches)
Max. width:	120 mm	(4.72 inches)
Min. width:	25.4 mm	(1.00 inches)
Max. web thickness:	175 μ m	(0.007 inches)

The maximum recommended media thickness is 175 μ m. Thicker media may be used, but print quality will be reduced. The stiffness is also important and must be balanced against thickness to maintain print quality.

Caution!

Any external media supply should be well protected against sand, grit, etc. Even very small but hard particles may cause severe harm to the printhead.

Media

Non-Adhesive Strip



← a ⇒ **Media Width**

Maximum:

120.0 mm (4.72 inches)

Minimum:

25.4 mm (1.00 inches)

Media Type Setup

- Fix length strip
- Var length strip

Media, cont.

Self-Adhesive Strip

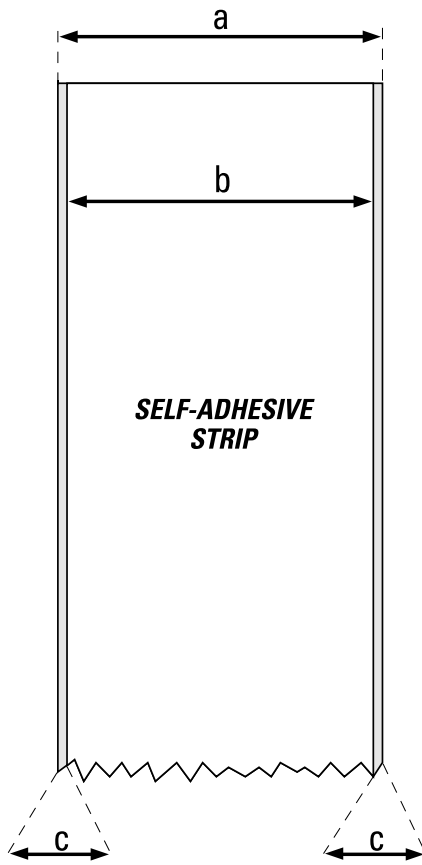

⇐ a ⇒ **Media Width** (including liner)

Maximum: 120.0 mm (4.72 inches)

Minimum: 25.4 mm (1.00 inches)

⇐ b ⇒ **Liner**

The liner must not extend more than a total of 1.6 mm (0.06 inches) outside the face material and should protrude equally on both sides.

⇐ c ⇒ **Media Width** (excluding liner)

Maximum: 118.4 mm (4.66 inches)

Minimum: 23.8 mm (0.94 inches)

Media Type Setup

- Fix length strip
- Var length strip

This type of media is not suitable for use with a cutter.

Media, cont.

Self-Adhesive Labels

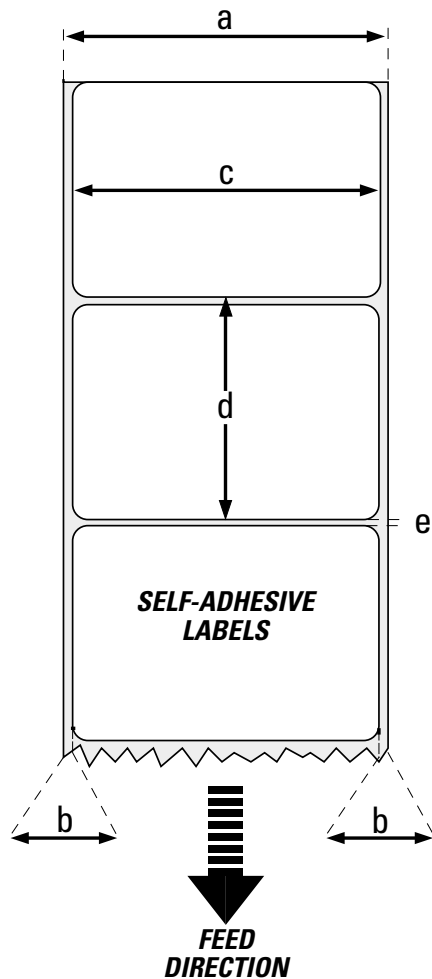

⇐ a ⇒ **Media Width** (including liner)

Maximum: 120.0 mm (4.72 inches)

Minimum: 25.4 mm (1.00 inches)

⇐ b ⇒ **Liner**

The liner must not extend more than a total of 1.6 mm (0.06 inches) outside the labels and should protrude equally on both side. Recommended min. transparency: 40% (DIN 53147).

⇐ c ⇒ **Label Width** (excluding liner)

Maximum: 118.4 mm (4.66 inches)

Minimum: 23.8 mm (0.94 inches)

⇐ d ⇒ **Label Length**

Maximum (8 dots/mm)¹: 1875 mm (73.8 inches)

Maximum (11.81 dots/mm)¹: 1250 mm (49.2 inches)

Minimum (all): 10 mm (0.39 inches)

⇐ e ⇒ **Label Gap**

Maximum: 10.0 mm (0.39 inches)

Recommended: 1.6 mm (0.06 inches)

Minimum: 1.2 mm (0.05 inches)

The adjustable label stop sensor must be able to detect the extreme front and rear edges of the labels. Therefore, do not use a larger inner core radii than can be compensated for by adjusting the sensor's position, that is, approximately 50 mm (1.97 inches).

Media Type Setup

- Label (w gaps)

¹/ The last third of a label (or the equivalent) cannot be used for printing, that is, the maximum print length is 1250 mm (49.2 inches) at 8 dots/mm and 833 mm (32.8 inches) at 11.81 dots/mm.

Media, cont.

Tickets with Gap

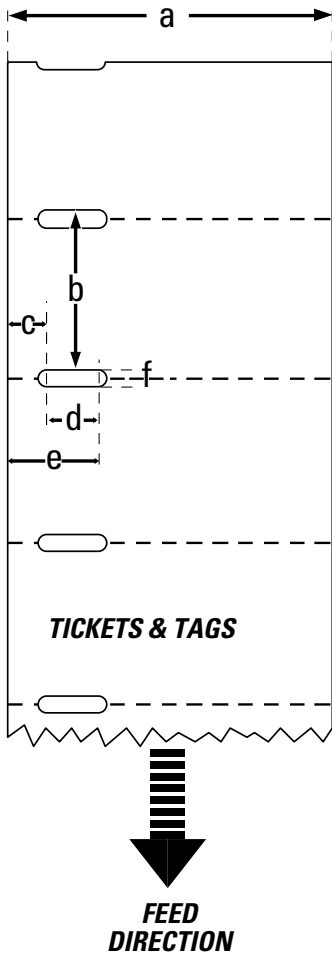

⇐ a ⇒ **Media Width**

Maximum:	120.0 mm	(4.72 inches)
Minimum:	25.4 mm	(1.00 inches)

⇐ b ⇒ **Copy Length**

Maximum (8 dots/mm) ¹ :	1875 mm	(73.8 inches)
Maximum (11.81 dots/mm) ¹ :	1250 mm	(49.2 inches)
Minimum (all):	10 mm	(0.39 inches)

⇐ c ⇒ **Detection Slit Start**

The restriction of the minimum slit length must be observed and the slit must not break the inner edge of the media.

⇐ d ⇒ **Detection Slit Length**

The length of the detection slit (excluding corner radii) must be minimum 5.0 mm (0.20 inches).

⇐ e ⇒ **Detection Slit End**

Provided the restrictions of the minimum slit length and slit start are observed, the distance from the inner edge of the media to the outer end of the slit (excluding corner radius) may be maximum 50 mm (1.97 inches).

⇐ f ⇒ **Detection Slit Height**

Maximum:	10.0 mm	(0.39 inches)
Recommended:	1.6 mm	(0.06 inches)
Minimum:	1.2 mm	(0.05 inches)

Perforation

Do not allow any perforation to break the edge of the media as this may cause the media to split and jam the printer.

Media Type Setup

- Ticket (w gaps)

¹/. The last third of a label (or the equivalent) cannot be used for printing, that is, the maximum print length is 1250 mm (49.2 inches) at 8 dots/mm and 833 mm (32.8 inches) at 11.81 dots/mm.

Media, cont.

Tickets with Black Mark

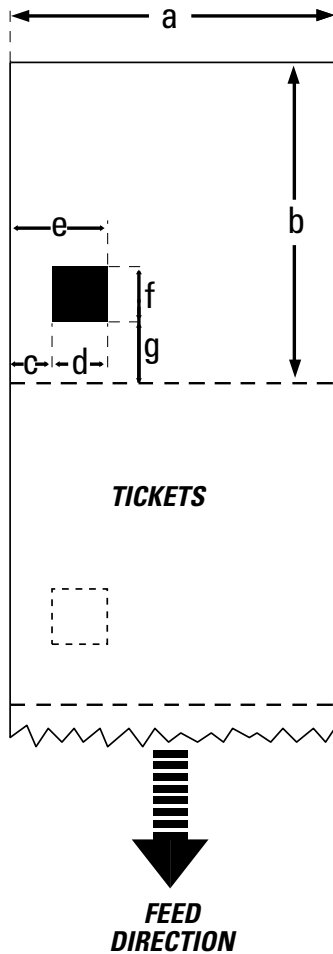

⇐ a ⇒	Media Width		
	Maximum:	120.0 mm	(4.72 inches)
	Minimum:	25.4 mm	(1.00 inches)
⇐ b ⇒	Copy Length		
	Maximum (8 dots/mm) ^{1/} :	1875 mm	(73.8 inches)
	Maximum (11.81 dots/mm) ^{1/} :	1250 mm	(49.2 inches)
	Minimum (all):	10 mm	(0.39 inches)
⇐ c ⇒	Black Mark Offset		
	Max. offset:	40 mm	(1.57 inches)
	Min. offset:	0 mm	(0.0 inches)
⇐ d ⇒	Black Mark Width		
	Minimum detectable width:	10 mm	(0.4 inches)
⇐ e ⇒	Black Mark End		
	No restriction, but the LSS cannot detect the mark more than 50 mm (1.97 inches) from the inner edge of the media.		
⇐ f ⇒	Black Mark Height		
	Commonly used height:	12.5 mm	(0.5 inches)
	Minimum:	5.0 mm	(0.2 inches)
⇐ g ⇒	Black Mark Y-Position		
	It is recommended to place the black mark as close to the front edge of the ticket as possible and use a negative Stop Adjust value to control the media feed, so the tickets can be properly torn or cut off (see Chapter 7).		

Perforation

It is recommended not to allow possible perforation to break the edges of the media. Else there is a small risk that the web may be partly separated before printing, causing a media jam.

Black Mark Color

The mark should be non-reflective carbon black on a whitish background.

Important! Preprint that may *interfere* with the detection of the black mark should be avoided on the back of the media. However, the LBLCOND instruction allows the sensor to be temporarily disabled to avoid unintentional detection, see Intermec Fingerprint manuals.

Media Type Setup

- Ticket (w mark)

^{1/}. The last third of a label (or the equivalent) cannot be used for printing, that is, the maximum print length is 1250 mm (49.2 inches) at 8 dots/mm and 833 mm (32.8 inches) at 11.81 dots/mm.

Transfer Ribbons

Important!

Intermec thermal transfer ribbons are engineered specifically for the EasyCoder printheads.

Intermec offer three types of thermal transfer ribbons optimized for different purposes:

- ***General Purpose (GP)/Standard & Basewax*** transfer ribbons allow high speed printing and give a good printout, but are somewhat sensitive to smearing. They may be the best choice for uncoated and coated papers.
- ***High Performance (HP)/Premium*** transfer ribbons allow high speed printing and give a highly readable and defined printout on most face materials with smooth surfaces. They have good “smear resistance” and are most suitable for intricate logotypes and images on matte-coated papers and synthetic face materials.
- ***High Resistance (HR)/Super Premium*** transfer ribbons give an extremely durable printout, which is resistant to most chemical agents and high temperatures. However, such transfer ribbons set high demands on the receiving face material, which must be very smooth, such as polyesters.

The use of HR/Super Premium ribbons requires the print speed and the energy supplied by the printhead to be controlled with great accuracy according to the receiving face material. Custom-made setup options adapted for special applications can also be created. Consult your Intermec distributor.

CPU Board

Accessing the CPU Board

WARNING!

Disconnect the power cord before removing the cover. Dangerous voltage!



The CPU board is situated in the electronics compartment on the left side of the printer's center section. To gain access to the electronics compartment, proceed as follows:

- Switch off the printer and disconnect the power cord. The CPU board contains power supply circuits with dangerous voltage.
- Remove the four #T10 Torx screws situated along the lower edge of the cover plate as indicated on the illustration below.
- Open the right-hand door and remove the four #T10 Torx screws at the top of the cover plate.
- Remove the cover plate.
- Reassemble in reverse order.

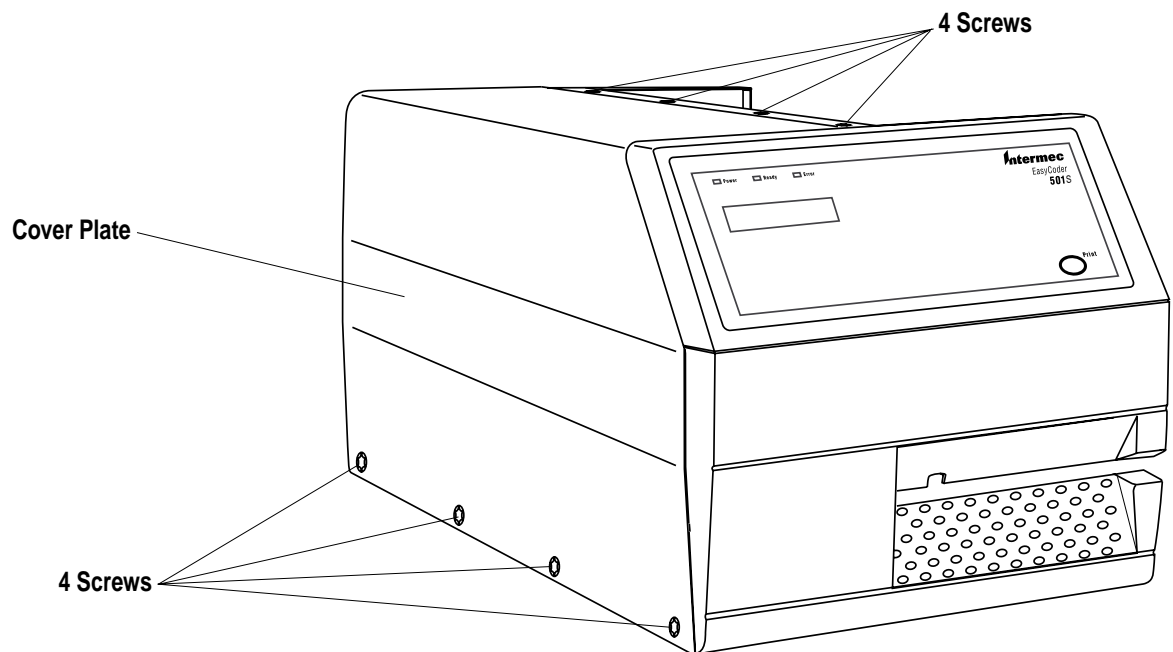

Safety Instructions

The CPU board contains a number of potentiometers for controlling various sensors. It also contains straps and circuits for setting the type of communication on the standard serial port "uart:", see Appendix 4.

Before touching the CPU board, carefully read this:

- Check that the power on control lamp at the top/front corner of the board is **off**. If not, disconnect the power cord.
- Take precautions to prevent electrostatic discharge
- Only use non-conductive tools. There is low-voltage power on the CPU board even when the printer is switched off and disconnected.

Potentiometers

The CPU board is fitted with four potentiometers with the following functions:

- Display contrast adjustment (see Chapter 13)
- Label stop sensor (LSS) adjustment
- Label taken sensor (LTS) adjustment (not used in this model)
- Ribbon end sensor (R-End) adjustment

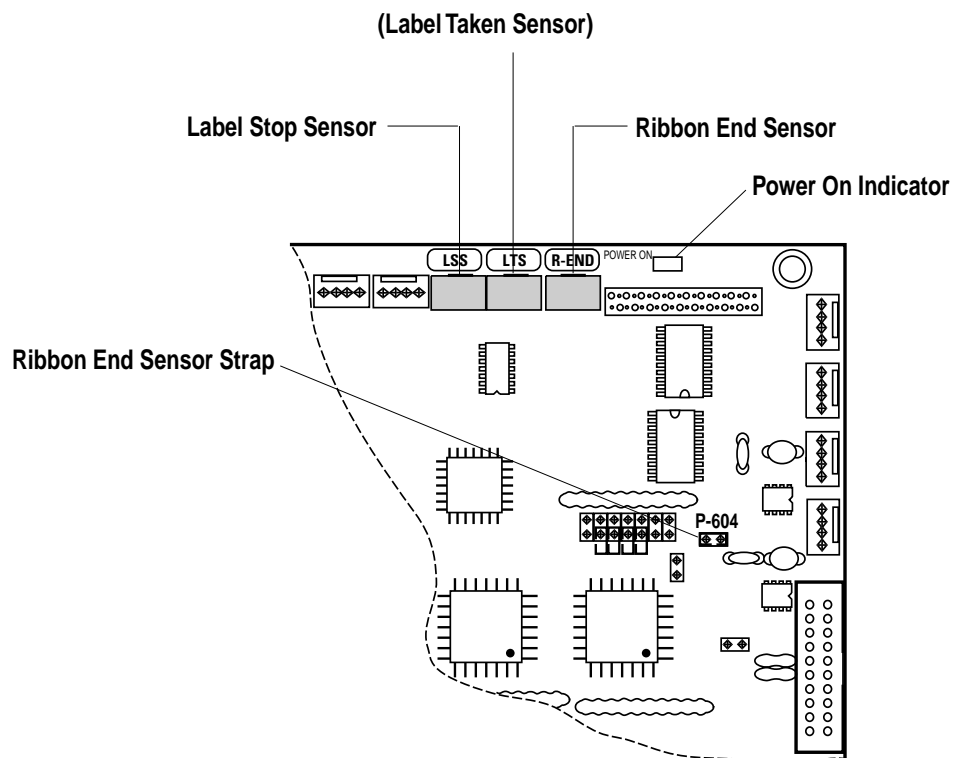

Potentiometers, cont.

Three potentiometers are situated along the top edge of the CPU board and can only be accessed after the left-hand cover plate has been removed. Normally, they do not require any adjustment.

- **Label Stop Sensor potentiometer**

This potentiometer is used in connection with the Setup option in Intermec Shell Standard for adjusting the sensitivity of the label stop sensor, for example according to the transparency of various brands of liner. In most cases, it will be sufficient to use the adjustment method offered in Intermec Shell Standard and by the Testfeed facility.

- **Label Taken Sensor potentiometer**

This potentiometer has no use because the label taken sensor is not supported by the firmware of EasyCoder 501 S.

- **Ribbon End Sensor potentiometer**

The ribbon end sensor is situated at the rear part of the printing mechanism. It emits a narrow beam of light and detects when there is no more thermal transfer ribbon left to stop the light from being reflected back from the mirror plate. This sensor is factory-adjusted and should normally not require any further adjustment, except after possible replacement.

The light intensity of the emitter can be changed between two values by means of fitting or removing a strap on P-604 (strap fitted = increased intensity).

This sensor is omitted if the printer is not fitted with any transfer ribbon mechanism.

Before changing the setting of a potentiometer, always make sure that the corresponding sensor is clean, free from obstructions (for example pieces of labels or adhesive residue), and properly aligned.

Interfaces

Standard Interface "uart1:"

UART is an abbreviation for Universal Aynchronous Receiver and Transmitter

All EasyCoder 501 printer models are fitted with a DB25pin male interface connector on their rear plates (communication port "uart1:"). This connector can be used for an RS-232, an RS-422, or a 20 mA current loop interface depending on how the CPU board is strapped. In the latter two cases, additional circuits must be fitted. The configuration of the connection cable is also important.

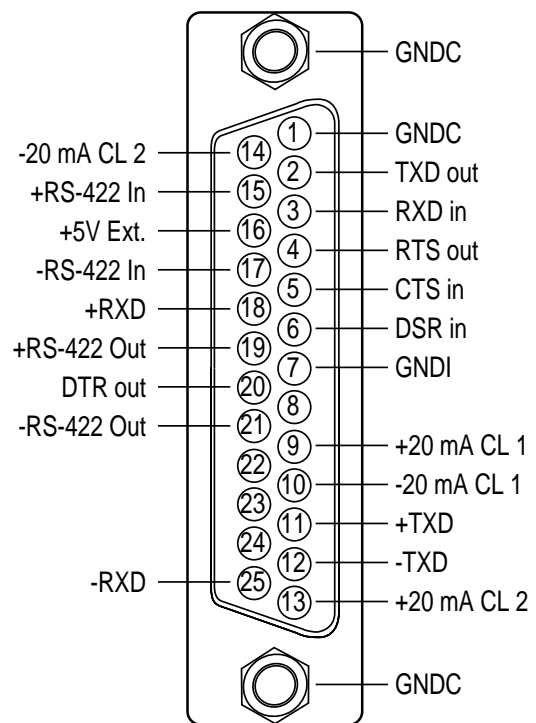
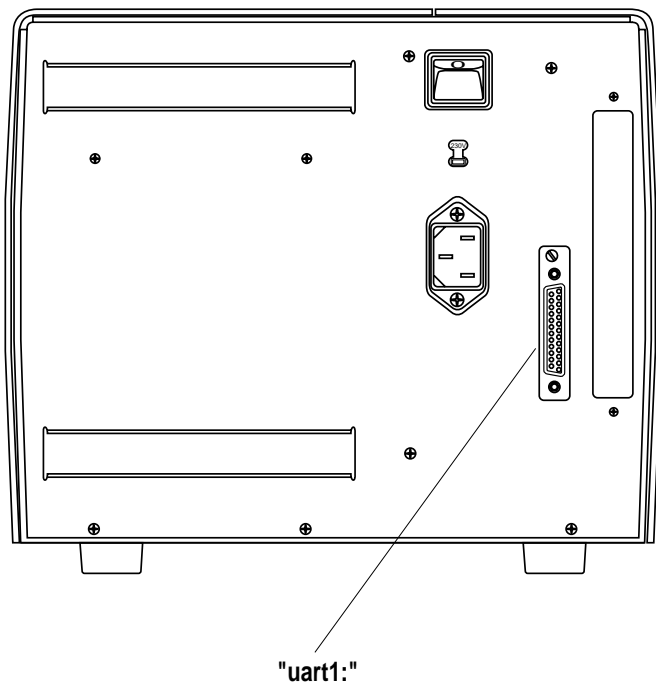

Signals on the printer's communication port "uart1:"

If the printer is ordered without any connection cable, a suitable cable can be procured locally and, if necessary, be modified according to the pinout descriptions in this chapter.

IMPORTANT!

A shielded communication cable is required in order to comply with the FCC/DOC approval and to avoid the risk of interference to radio communications.

Standard Interface "uart1:", cont.

RS-232

RS-232 is the most common interface for serial communication with computers over short distances. The transmission can only take place between one transmitter and one receiver. The most simple form of two-way communication only requires a 3-wire cable. The maximum transmission distance is about 10 to 15 metres (33 to 49 ft.) and the maximum transmission speed is 19,200 baud.

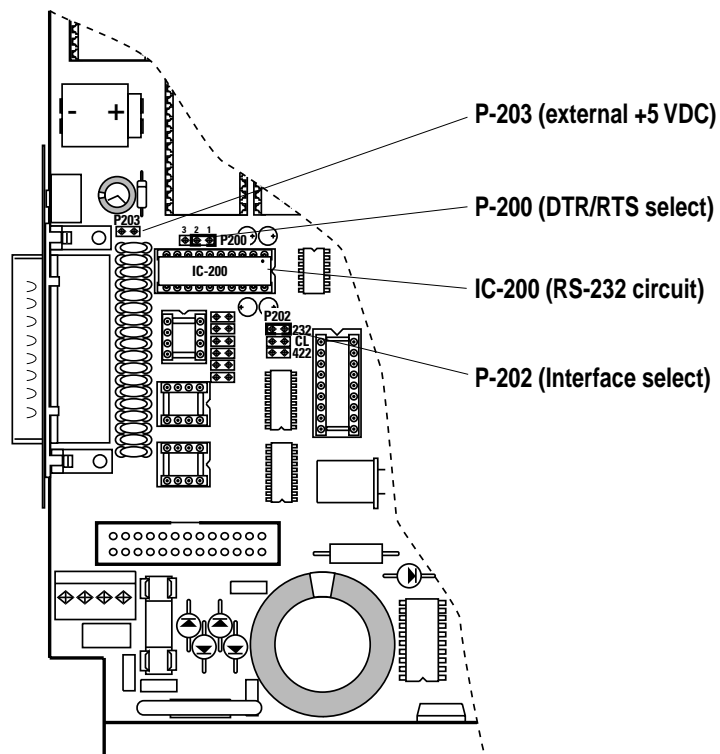

- An RS-232 circuit must be fitted on IC-200 (fitted as standard).
- A jumper must be fitted on **uppermost position** of P-202.
- Any RS 422 circuit on IC-207, optocouplers on IC-205 and IC-206 (optional) and straps on P-204–P-209 are of no consequence.

The following hardware straps can be fitted:

P-200 DTR-signal

Pin 1–2 DTR indicates printer turned on.

Pin 2–3 A copy of the flow signal RTS is produced.

P-203 External 5 Volt¹

Jumper fitted connects +5V to pin 16. **Caution! Max 200 mA.**

¹/₁. *Caution! Be careful not to enable the external 5V unintentionally, which may cause harm to the terminal, PC, or other device connected to this port!*

Standard Interface "uart1:", cont.

RS-232, cont.

This diagram shows the configuration of RS-232 cables between an EasyCoder 501 and a computer with either a DB-9pin or DB-25pin communication port. The cable should have a female DB-25pin connector at the printer side.

Host		EasyCoder 501			Host	
Signal	DB-9	DB-25	Signal	DB-25	DB-25	Signal
housing			housing			housing
		1	shield	1	1	shield
RXD	2	2	TXD	2	3	RXD
TXD	3	3	RXD	3	2	TXD
CTS ¹	8	4	RTS	4	5	CTS ¹
RTS	7	5	CTS	5	4	RTS
GND	5	7	Signal GND	7	7	GND
		16	+ 5V ²	16		
DSR	6	20	DTR	20	6	DSR

¹/. If the communication cable is not configured to transmit any CTS signal to the printer, a permanent CTS signal will automatically be produced.

²/. Requires a strap fitted on P-203, see previous page.

Standard Interface "uart1:", cont.

RS-422

RS-422 is a point-to-point interface for connection between one printer and one host computer over a distance of up to 1,200 metres (4,000 ft.) by use of a four-wire cable. The transmission is full duplex, that is, reception and transmission can take place simultaneously.

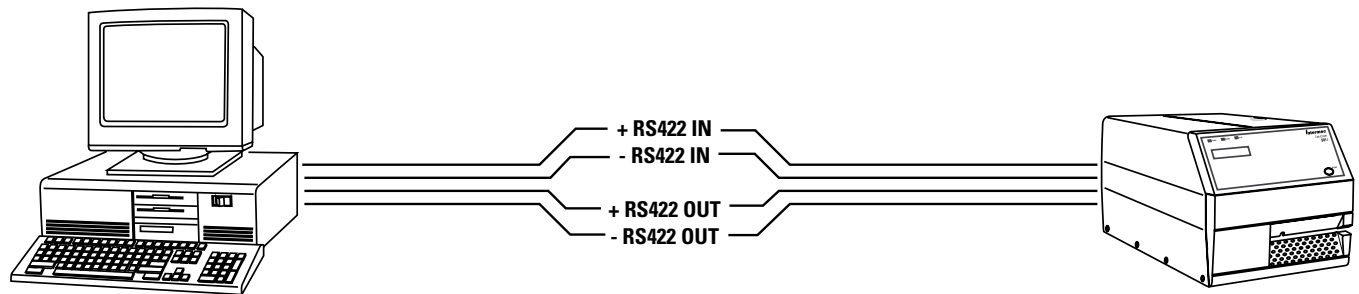

RS-422 connection between host computer and printer.

RS-422 requires an additional circuit and a number of straps to be fitted on the CPU board:

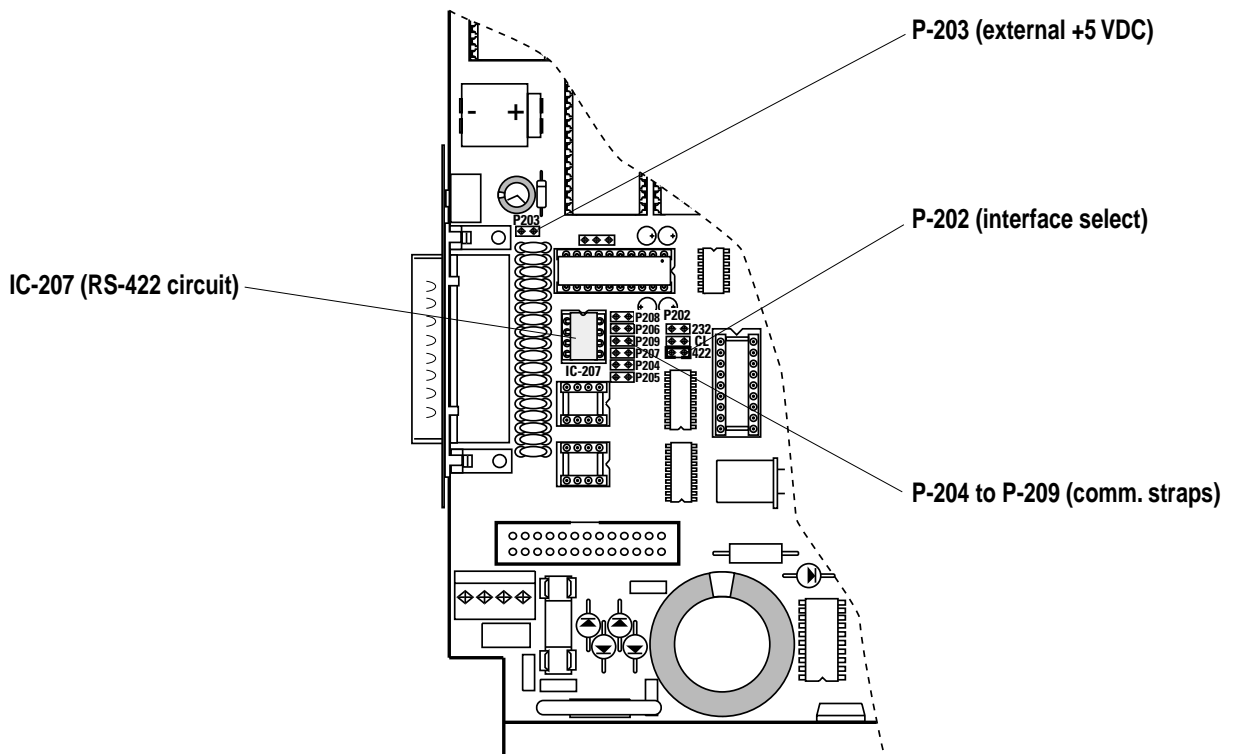

Standard Interface "uart1:", cont.

RS-422, cont.

On the CPU board, check:

- An optional RS-422 circuit must be fitted on **IC-207**.
- Jumper must be fitted on the **lowest** position of **P-202** to select RS-422.
- Jumper must be fitted on some of **P-204** to **P-209** according to the diagram below.
- Any RS-232 circuit on IC-200 (standard), jumper on P-200, and optocouplers on IC-205 and IC-206 (optional) are of no consequence.

P-203 External 5 Volt

Jumper fitted connects +5V to pin 16. *Caution! Max. 200 mA.* (Note that +5V requires an additional wire in the cable).

Be careful not to enable the external 5V unintentionally, which may cause harm to the terminal, PC, or other device connected to this port!

P-204 – P-209 Communication straps

Jumpers can be fitted on P-204, P-205, P-206, P-207, P-208, and/or P-209 in order to adapt the RS-422 communication to the host, as shown in the diagram below. Normally, jumpers should be fitted on P-205, P-207, and P-209.

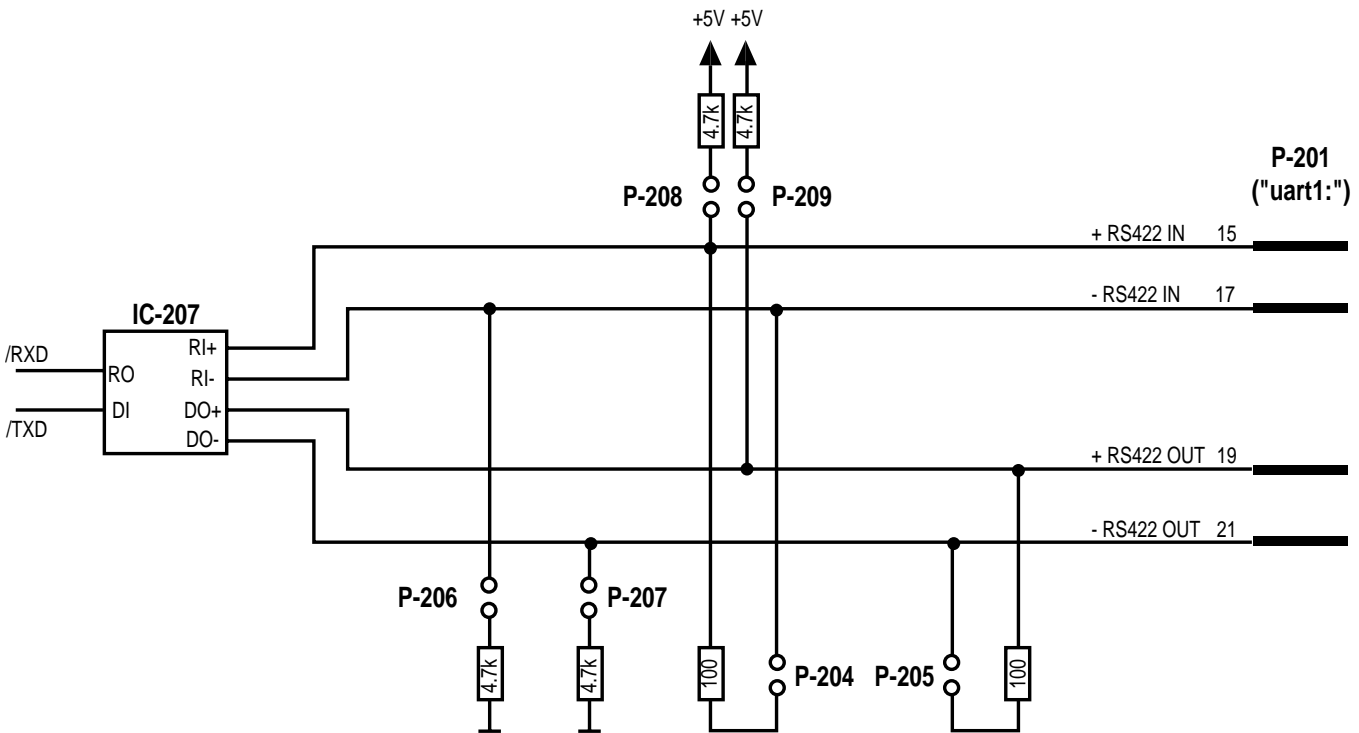

Standard Interface "uart1:", cont.

20 mA Current Loop

The 20 mA current loop interface is a single-ended, full duplex serial interface which uses current instead of voltage to transmit signals on a four-wire line. 20 mA current corresponds to a logical "0" and 0 mA corresponds to a logical "1".

Optocouplers are used to separate the transmission line from the internal logics of the printer and the host computer. Therefore this interface is suitable where electrical interference may occur, and for transmission over longer distances (up to 500 metres or 1,500 ft.).

Depending on the configuration of the connection cable between printer and host computer, the printer can work either active (that is, supplying the current) or passive. A transmission speed between 300 and 9,600 baud is recommended.

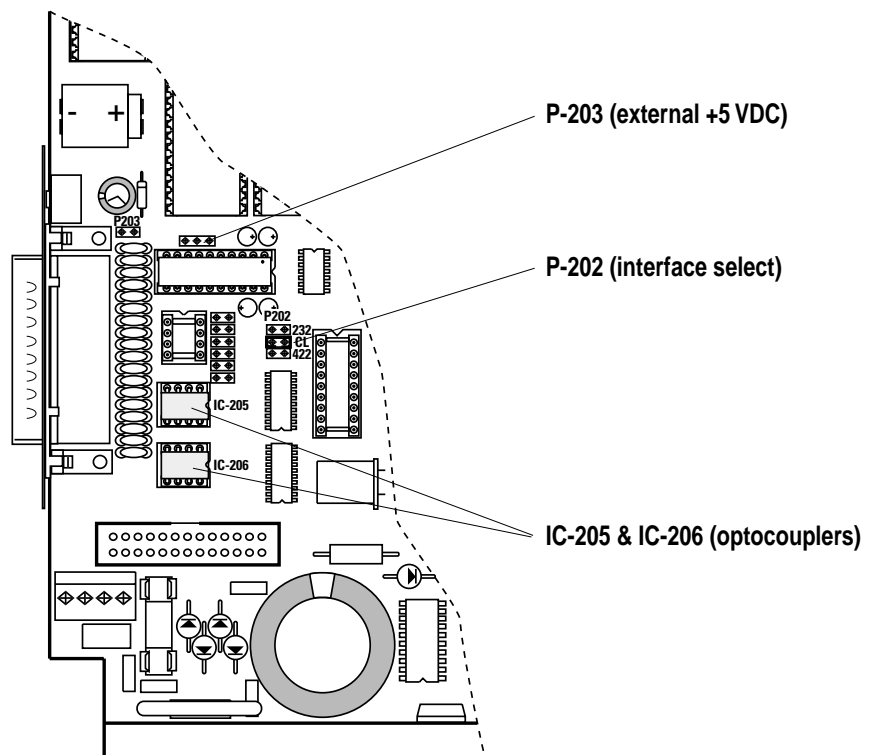

Standard Interface "uart1:", cont.

20 mA Current Loop, cont.

On the CPU board, check:

- Optocouplers must be fitted on **IC-205** and **IC-206**. These are not included as standard and must be ordered separately.
- Jumper must be fitted on **middle position of P-202** to select 20 mA current loop.
- Any RS-422 circuit fitted on IC-207 (optional), RS-232 circuit fitted on IC-200 (standard), and jumpers fitted on P-204 to P-209 or on P-200 are of no consequence.

P-203 External 5 Volt

Jumper fitted connects +5V to pin 16. **Caution! Max. 200 mA.**

Be careful not to enable the external 5V unintentionally, which may cause harm to the terminal, PC, or other device connected to this port!

Cable configuration

The printer end of the connection cable should have a DB-25pin female connector. The computer end of the cable depends on your type of computer.

The printer's connector contains the following signals:

Pin 9	+ 20 mA
Pin 10	- 20 mA
Pin 11	TXD +
Pin 12	TXD -
Pin 13	+ 20 mA*
Pin 14	- 20 mA*
Pin 16	+ 5 VDC, 200 mA (if jumper fitted on P-203)
Pin 18	RXD +
Pin 25	RXD -

*. *In case of printer being active receiver.*

Parallel Interface Board (option)

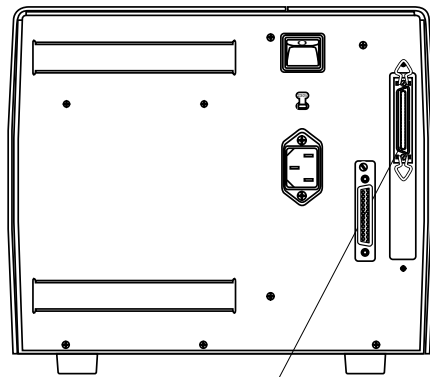

"centronics:"

The EasyCoder 501 S can optionally be fitted with a parallel interface board. The parallel port is addressed in Intermec Fingerprint as device "centronics:". Select "centronics:" as the standard IN port using the instruction SETSTDIO (by default, "uart1:" is std IN port)¹.

Interface Cable Connectors

Computer end: Depends on type of host computer.

Printer end: 36-pin IEEE 1284B Centronics socket

Pin	Signal Name	Remarks
1	/STROBE	
2-9	DATA 0-7	
10	ACK	
11	BUSY	
12	PE	
13	SELECT	
14-15	Not connected	
16-17	GND	
18	+5 VDC Ext	Max. 200 mA. Enabled by strap on P-2
19-30	GND	
31	/INPRM	
32	/ERROR	
33-35	Not connected	
36	/SLCTIN	
37-38	GND	Housing

Refer to the installation instructions for the Parallel Interface Board for further information.

¹/ Intermec Shell either automatically sets the correct standard IN and OUT port when an application is selected or prompts you to select one, see Chapter 9.

