

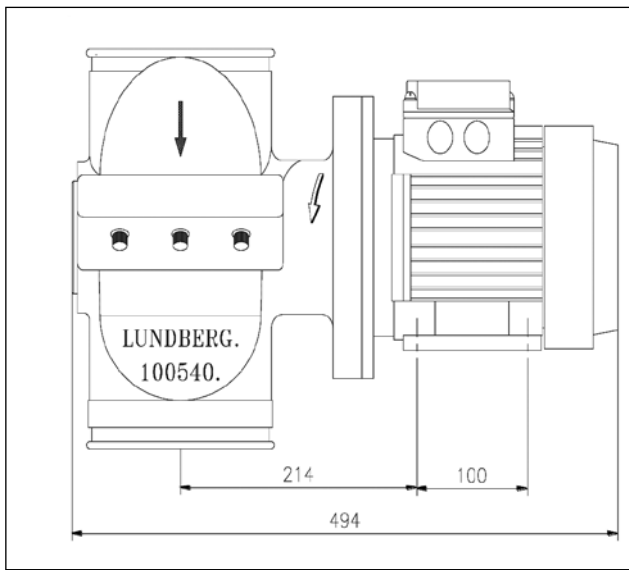

Granulator & Cutter GR140



Granulator housing	Cast iron.
Motor standard	0,75kW type M80, 1400/2800 rpm
Power	3x400V, 50Hz.
Nom. amperage	1,75A
Fuse	10 Amp.
Rotor standard	3 pcs. Hard-metal blades.
Rotor option	6-9-12 pcs. Hard-metal blades.
Piping	Ø160 mm. transfer
Transmission	Direct coupling
Weight incl. motor	32 kg
Weight excl. motor	22 kg
Surface treatment	Powder lacquering, RAL 5010
Noise level	60 dB (A)
Maximum capacity	2000 Kg/hour
Minimum thickness	10 microns

