

This publication supersedes and replaces any previous edition and revision. All rights reserved.
 No part of this publication may be reproduced, stored in a retrieval system or transmitted in any form
 or by any means, electronic, mechanical, photocopying, recording or otherwise, without permission
 of Tecnicam s.r.l. (Bologna - Italy).
 The technical data are not binding and may be subject to change without prior notice.

HV

High speed continuous motion horizontal cartoner

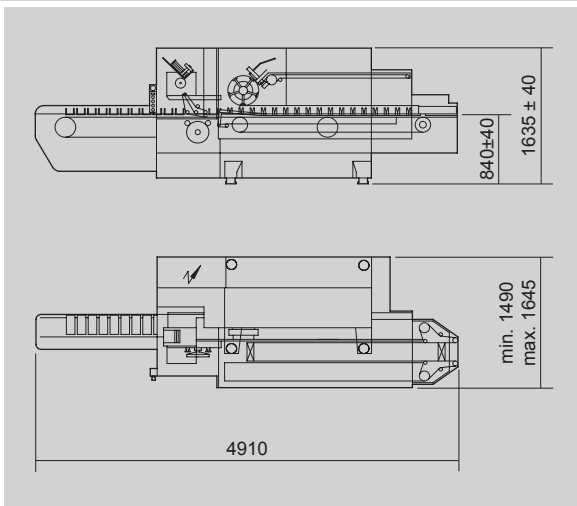
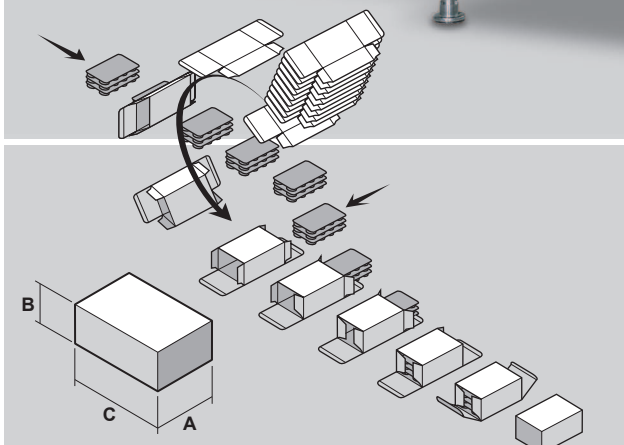

TECHNICAL DATA		HV 1	HV 2
Mechanical speed	STROKES/1'	max. 400	max. 260
Motors	KW	4.25	4.25
Power absorption	KW	5.20 (Hot-melt + 3.9)	5.20 (Hot-melt + 3.9)
Air consumption	NI/1'	16.9	16.9
Air pressure	bar	5+6	5+6
Gross weight	kg	~3000	~3000
Net weight	kg	~2500	~2500

Size range	HV 1		HV 2	
	min.	max.	min.	max.
A	20	95	20	160
B	12	70	12	70
C	70	230	70	230
A + B	-	165	-	200

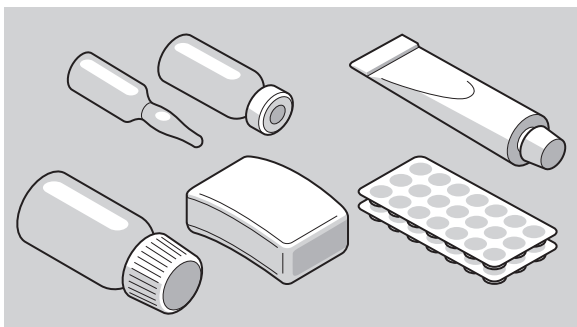

FM-HV-02-uk (10/11/2014)